

TEC.MO.[®]

Plasma torches and consumables



2013.05.E.GC

For **over 25 years TEC.MO.** is **world-leader** in manufacturing torches, consumables and accessories for plasma cutting.

We are specialized in copper machining, by means of sophisticated tools and equipments, which let us reach and keep a very highly qualified production level, our technicians having considerable and proved experience.

Our consumables are manufactured with Computerized Numerical Control and Multispindle lathes in order to obtain very accurate tolerances.

We keep under tight control the several operation schedules at any stage of the production process, each article passing through even 5 or 6 quality inspection tests before being stocked for available delivery.

Torch packages and heads are **tested one by one**, to grant the maximum reliability.

Our **comprehensive stockholding** of standard products enables **prompt** and **efficient** deliveries.

On request, we can manufacture any exclusive further part from print.

With the **laser marking** we can personalize our torch packages and consumables, and it's also possible to have these latter in clamp-shells, telescopic tubes or thermowelded plastic bags.

Our strong points are : **QUALITY – SERVICE – COOPERATION**

Da **oltre 25 anni TEC.MO.** è **leader mondiale** nella produzione di torce, parti di consumo e accessori per il **taglio plasma**.

Siamo specializzati nella lavorazione del rame, con attrezzature e macchine speciali, che ci hanno consentito di raggiungere e mantenere degli standard qualitativi altissimi, grazie alla grande e comprovata esperienza dei nostri tecnici.

I nostri particolari di consumo vengono prodotti su torni a controllo numerico e plurimandrini, con tolleranze molto precise. Si effettuano verifiche continue ad ogni stadio di lavorazione, ed ogni articolo subisce anche 5 o 6 tests prima di essere immagazzinato, pronto per la spedizione.

Torce e corpi torcia vengono **collaudati singolarmente** per garantirne la massima affidabilità.

Il nostro **importante stock** di materiale standard ci consente di effettuare le consegne in modo **rapido** ed **efficiente**.

Su richiesta, siamo in grado di produrre ulteriori particolari a disegno in esclusiva.

Possiamo personalizzare con la **marcatore laser** sia le torce che le parti di consumo, e queste ultime possono essere confezionate in bi-valve, tubi telescopici o sacchetti termo-saldati.

I nostri **punti di forza** sono : **QUALITA' – SERVIZIO - COLLABORAZIONE**

Hypertherm [®] _____	5
Thermal Dynamics [®] _____	11
Eurolok [®] _____	15
Unitorch [®] _____	17
Kjellberg [®] _____	19
Esab [®] L-Tec [®] _____	20
Miller [®] _____	21
Otc [®] _____	22
Saf [®] Fro [®] _____	23
Panasonic [®] _____	23
Smith-Merkle [®] _____	23
Autogen Ritter [®] _____	24
Binzel [®] _____	24
Cebora [®] _____	25
Ews [®] Lincoln [®] _____	31
Telwin [®] _____	34
Trafimet [®] _____	36
Circle cutting attachments _____	42
Central adaptors _____	43
End fittings _____	44
Accessories _____	45

HYPERTHERM®
POWERMAX 1000® T60/T60M®
POWERMAX 1250® T80/T80M®
POWERMAX 1650® T100/T100M®

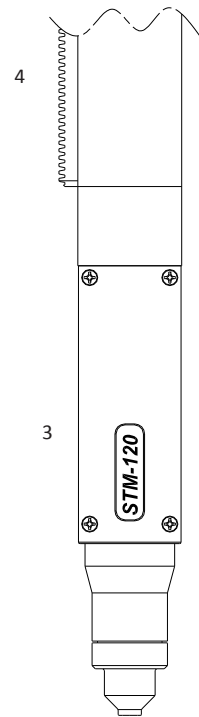
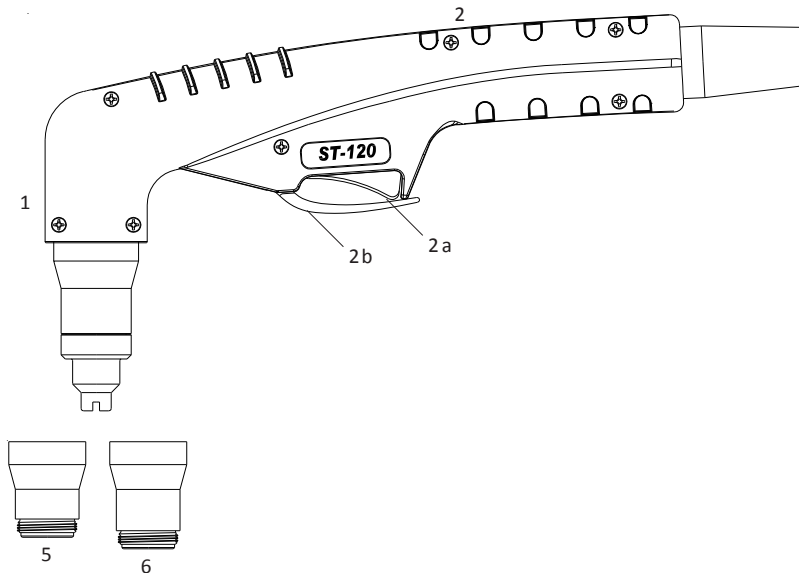
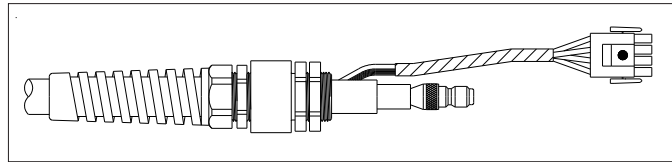

Consumables: see next page

No.	Code	Description	No.	Code	Description
1	03800	ST-120 Hand torch head		02800.60	O-Ring
2	09705	Handle with switch	4	07216	Positioning tube with rack
2a	07301.20	Switch	5	60495	Retaining cap, 40-80A
2b	09605.42	Safety tab	6	60496	Retaining cap, 100A
3	03810	STM-120 machine torch head			

Torches and leads

POWERMAX 1000® T60/T60M®
POWERMAX 1250® T80/T80M®

Code	Description	Code	Description
03820CX-HY	ST-120 Hand torch, 7.5m, 25'	03830CX-HY	STM-120 Machine torch, 7.5m, 25'
03825CX-HY	ST-120 Hand torch, 15m, 50'	03835CX-HY	STM-120 Machine torch, 15m, 50'
09781CX-HY	Lead assembly, hand, 7.5m, 25'	09791CX-HY	Lead assembly, machine, 7.5m, 25'
09786CX-HY	Lead assembly, hand, 15m, 50'	09796CX-HY	Lead assembly, machine, 15m, 50'

Torches and leads

POWERMAX 1650® T100/T100M®

Code	Description	Code	Description
03821CX-HY	ST-120 Hand torch, 7.5m, 25'	03831CX-HY	STM-120 Machine torch, 7.5m, 25'
03826CX-HY	ST-120 Hand torch, 15 m, 50'	03836CX-HY	STM-120 Machine torch, 15m, 50'
09780CX-HY	Lead assembly, hand, 7.5m, 25'	09790CX-HY	Lead assembly, machine, 7.5m, 25'
09785CX-HY	Lead assembly, hand, 15m, 50'	09795CX-HY	Lead assembly, machine, 15m, 50'

HYPERTHERM®

POWERMAX 1000® T60/T60M®
 POWERMAX 1250® T80/T80M®
 POWERMAX 1650® T100/T100M®
 POWERMAX 1100® RT80/RT80M®
 RT60/RT60M®

40-80 A

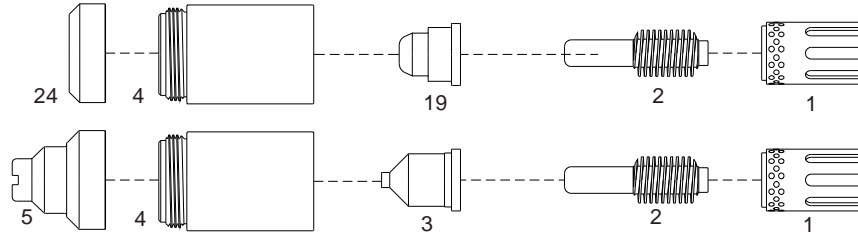

100 A

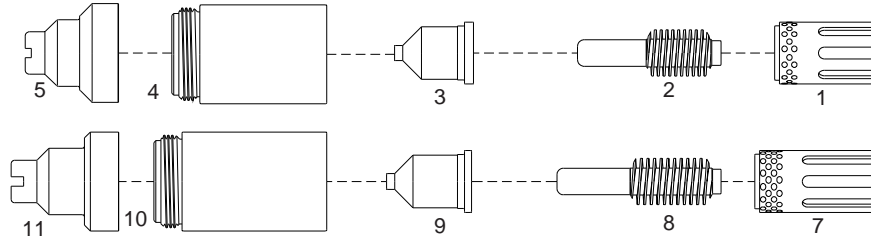

40-80 A

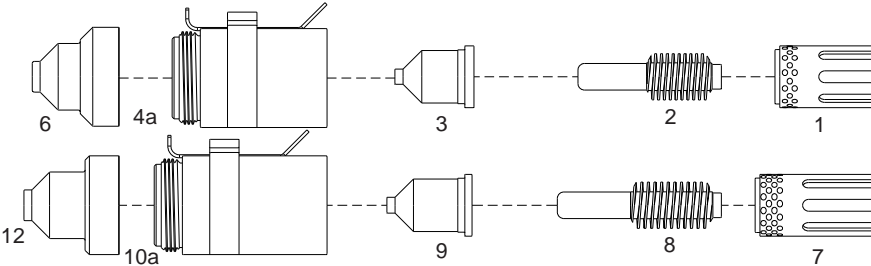

100 A

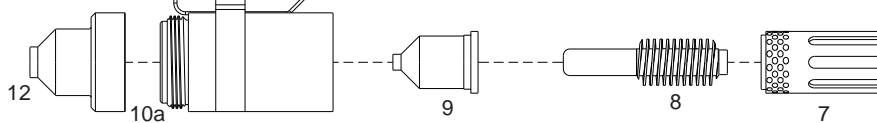

40-80 A

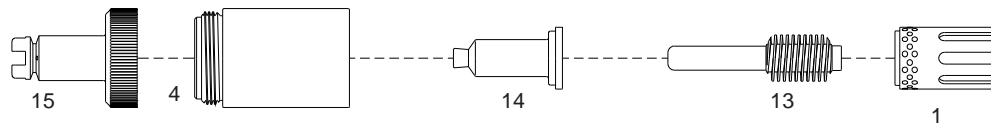
**TEC.MO DESIGN**

100 A

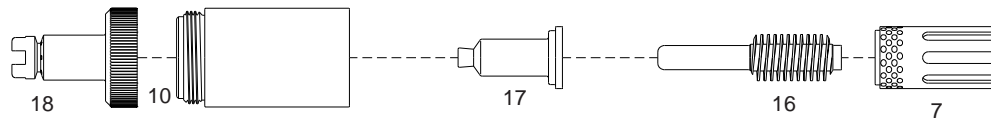

40-80 A

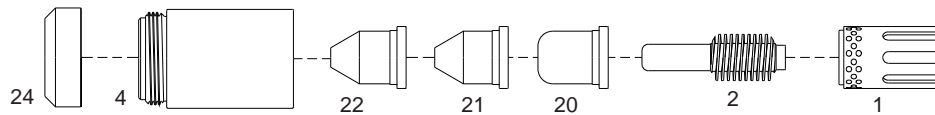

100 A

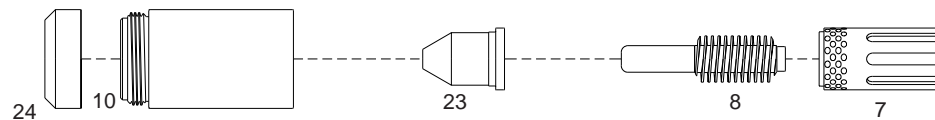

No.	Ref.	Code	Description	No.	Ref.	Code	Description
1	120925	60043	Swirl ring Max Life 40/80A	10a	220206	60307H	Retaining cap 100A OHMIC
	120925	60043E	Swirl ring 40/80A	11	220065	51983/TD	Hand shield 100A
2	120926	52675	Electrode 40-80A	12	220047	51984/TD	Machine shield 100A
	120926	52675BM	Electrode 40-80A BiMetal	13	TD	52675L	Extended electrode 40-80A
3	120932	51405.10	Tip 40A shielded	14	TD	51405L.10	Extended tip 40A shielded
	120931	51405.12	Tip 60A shielded		TD	51405L.12	Extended tip 60A shielded
	120927	51405.14	Tip 80A shielded		TD	51405L.14	Extended tip 80A shielded
4	120928	60304	Retaining cap 40/80A	15	TD	60505L	Extended shield 40-80A
4a	220061	60304H	Retaining cap 40/80A OHMIC	16	TD	52676L	Extended electrode 100A
5	120929	51981/TD	Hand shield 40/80A	17	TD	51406L.15	Extended tip 100A shielded
6	120930	51982/TD	Machine shield 40/80A	18	TD	51983L	Extended shield 100A
7	220051	60044	Swirl ring Max Life 100A	19	220329	51407	Tip 30-50A Precision Cut
	220051	60044E	Swirl ring 100A	20	220006	51402	Tip 40A unshielded
8	220037	52676	Electrode 100A	21	220007	51403	Tip 60A unshielded
	220037	52676BM	Electrode 100A BiMetal	22	120980	51404	Tip 80A unshielded
9	220011	51406	Tip 100A shielded	23	220064	51408	Tip 100A unshielded
10	220048	60307	Retaining cap 100A	24	120979	51939	Deflector

**HYPERTHERM®
POWERMAX 45® H45®**

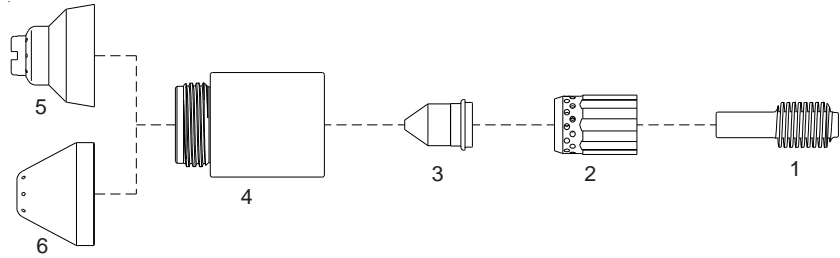

No.	Ref.	Code	Description	No.	Ref.	Code	Description
1	220669	52574	Electrode	4	220713	60305	Retaining cap
2	220670	60041	Swirl ring	5	220674	51923	Hand shield
3	220671	51206	Tip 45A	6	220673	51924	Machine shield

HYPERTHERM® POWERMAX 1000/1250/1650® HRT® MRT® Retrofit torch
POWERMAX 65® H65® M65®
POWERMAX 85® H85® M85®
POWERMAX 105® H105® M105®

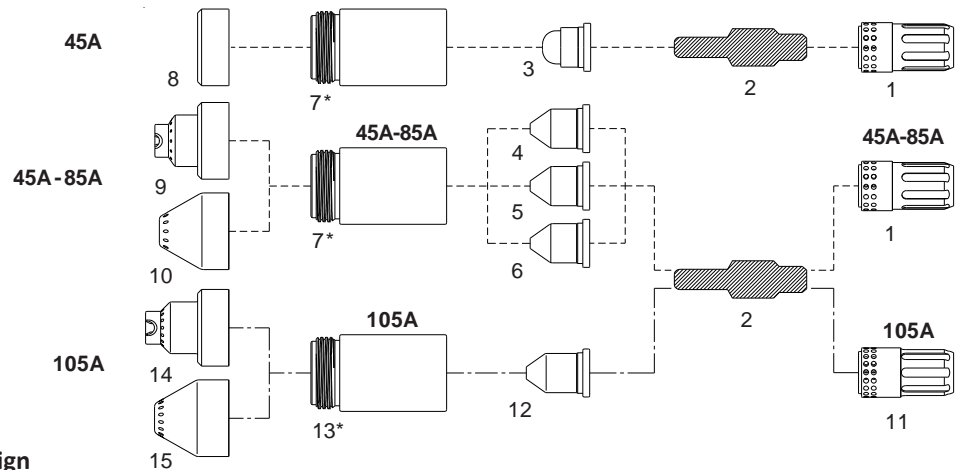

* Differ from OEM design

No.	Ref.	Code	Description	No.	Ref.	Code	Description
1	220857	60042	Swirl ring 45-85A	9	220818	51921	Hand shield 45-85A
2	220842	N/A	Electrode 45-100A	10	220817	51922	Machine shield 45-85A
3	220930	51415	Tip 45A Precision Cut	11	220994	60040	Swirl ring 105A
4	220941	51416	Tip 45A (for use with item # 7)	12	220990	51419	Tip 100A (for use with item # 13)
5	220819	51417	Tip 65A (for use with item # 7)	13*	220854/105	60309B	Retaining cap 105A
6	220816	51418	Tip 85A (for use with item # 7)	14	220992	51926	Hand shield 105A
7*	220854/85	60309A	Retaining cap 45-85A	15	220993	51927	Machine shield 105A
8	220955	51928	Deflector				

**HYPERTHERM®
MAX 20®
PAC110®**

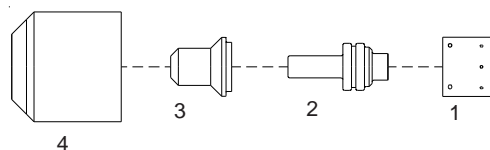

No.	Ref.	Code	Description	No.	Ref.	Code	Description
1	020239	60035	Swirl ring	3	020381	51216	Extended tip ø 0,73 - .029
2	020382	52571	Extended electrode	4	020218	60300	Retaining cap

HYPERTHERM®
POWERMAX 350® PAC110®
POWERMAX 380® PAC110T®

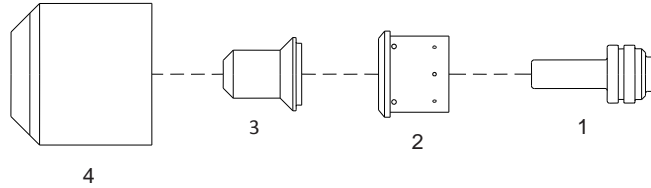

No.	Ref.	Code	Description	No.	Ref.	Code	Description
1	020382	52571	Extended electrode	3	120504	51217	Extended tip \varnothing 0,81 - .032
2	220013	60037	Swirl ring	4	220016	60300	Retaining cap

HYPERTHERM®
POWERMAX 600®
PAC123T/M®

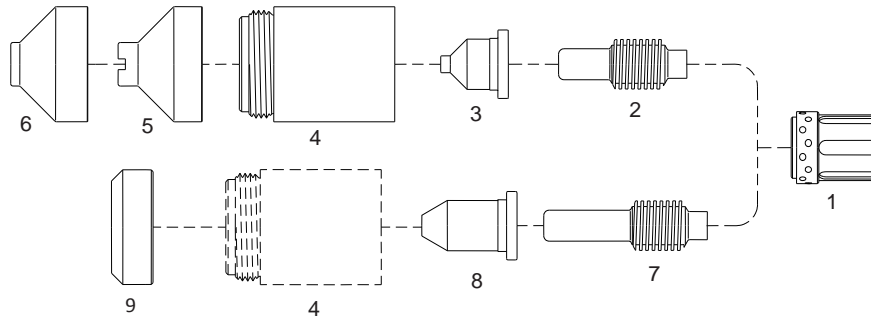

No.	Ref.	Code	Description	No.	Ref.	Code	Description
1	120576	60047	Swirl ring	6	120827	51979/TD	Machine shield
2	120573	52575	Electrode	7	120574	52576	Extended electrode
3	120826	51214	Tip 40A	8	120606	51208	Extended tip 35A
4	120600	60316	Retaining cap	9	120303	51987/TD	Deflector
5	120828	51978/TD	Hand shield				

HYPERTHERM®
POWERMAX 800®
MAX 42/43®/40CS®
PAC121PT/M®
PAC121TS/M®

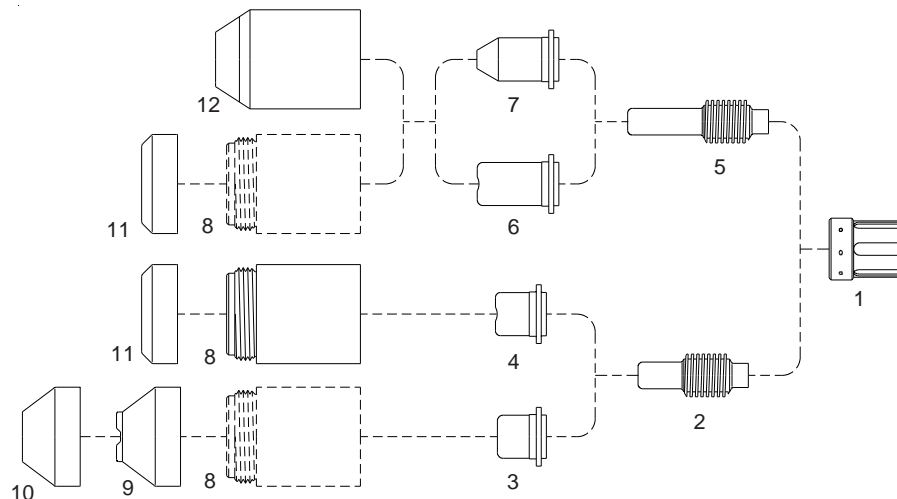

No.	Ref.	Code	Description	No.	Ref.	Code	Description
1	020361	60046	Swirl ring	7	120305	51203	Tip pipe saddle
2	120573	52575	Electrode (replaces 020351)	8	120301	60313/TD	Retaining cap
3	120438	51204	Tip 40A	9	120283	51985/TD	Hand shield
	120282	51201	Tip 50A	10	120326	51986/TD	Machine shield
4	020395	51211	Tip 50A	11	120303	51987/TD	Deflector
5	120574	52576	Extended electrode (replaces 020547)	12	020930	60303	Retaining cap
6	120304	51202	Extended tip				

**HYPERTHERM®
POWERMAX 900®
PAC125T/M®**

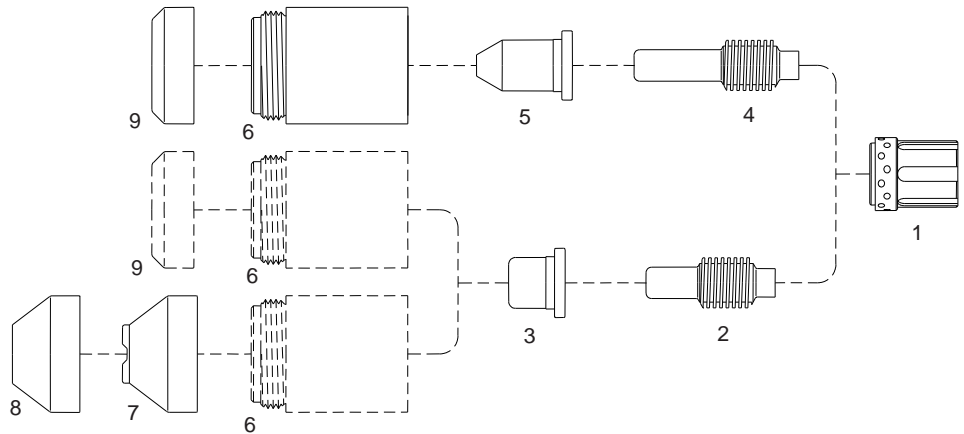

No.	Ref.	Code	Description	No.	Ref.	Code	Description
1	120576	60047	Swirl ring	2	120573	52575	Electrode
2	120573	52575	Electrode	3	120577	51207	Tip 55A shielded
3	120577	51207	Tip 55A shielded	4	120574	52576	Extended electrode
4	120574	52576	Extended electrode	5	120606	51208	Extended tip 35A
5	120606	51208	Extended tip 35A	6	120600	60316	Retaining cap
				7	120601	51985/TD	Hand shield
				8	120602	51986/TD	Machine shield
				9	120303	51987/TD	Deflector

**HYPERTHERM®
MAX 40®
PAC140®
HT40®**

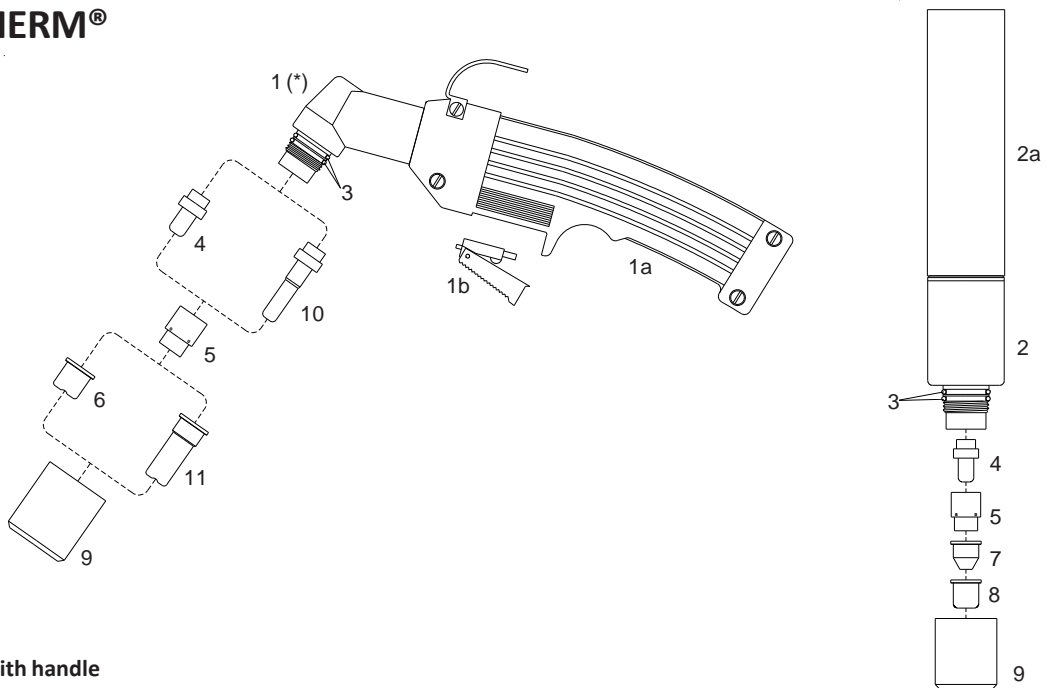

(*) complete with handle

No.	Ref.	Code	Description	No.	Ref.	Code	Description
	057112	07320	Hand torch 25'	3	026016	07300.60	O-Ring
	057113	07330	Hand torch 50'	4	020103	52512/L	Electrode
		07340	Machine torch 25'	5	020101	60001	Swirl ring
		07350	Machine torch 50'	6	020115	51100	Tip, hand torch
1	057114	07300	Hand torch body (*)	7	020131	51098	Pipe saddle tip, machine torch
1a		07301	Handgrip with switch	8	020102	51099	Tip, machine torch
1b		07301.20	Switch	9	020104	60301	Retaining cap
2	020114	07310	Machine torch body	10	020467	52513/L	Extended electrode
2a	020206	07315	Machine handle	11	020466	51102	Extended tip

HYPERTHERM®

MAX 80/100®

PAC130®

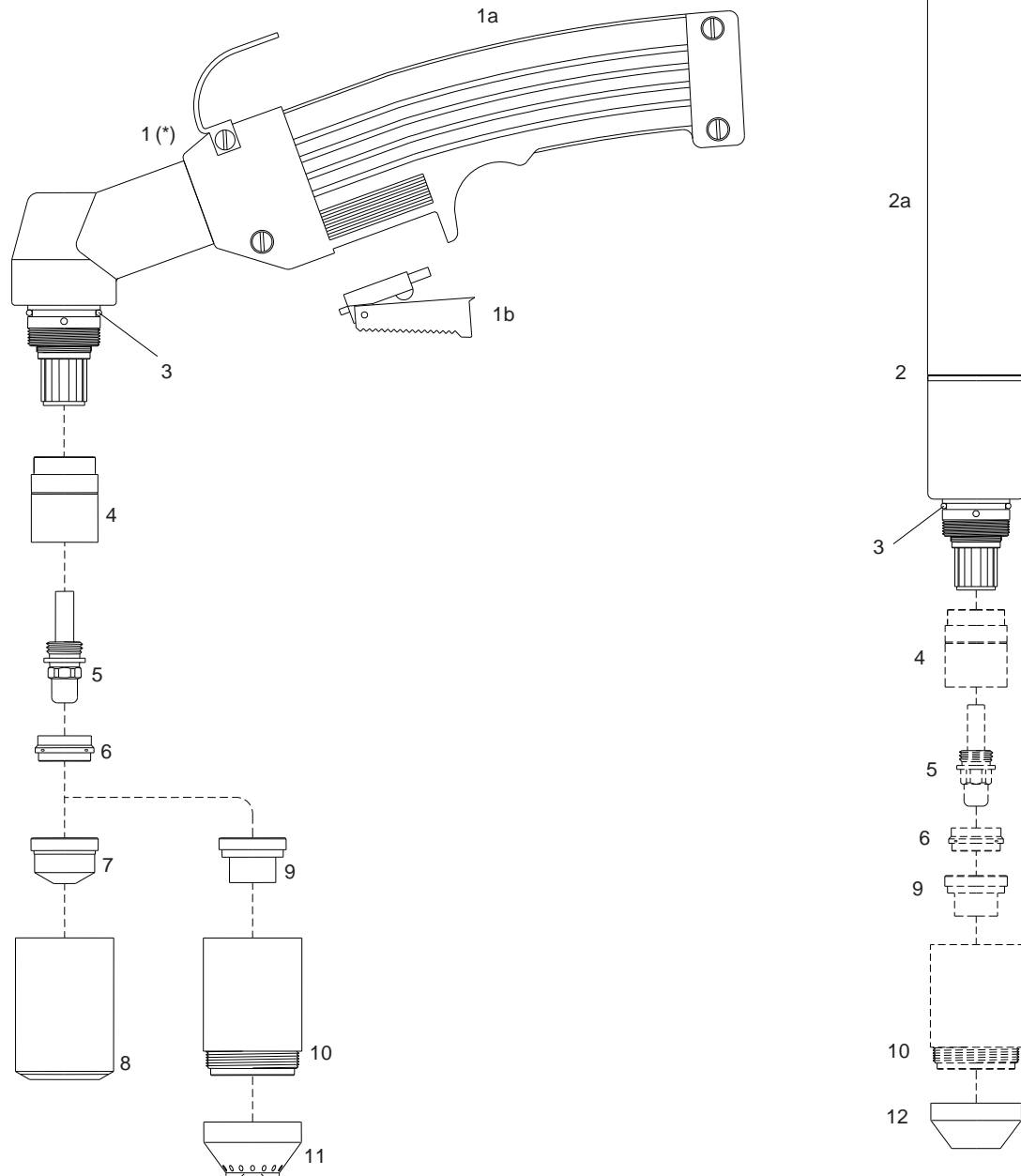

(*) complete with handle

No.	Ref.	Code	Description	No.	Ref.	Code	Description
	059076	07420	Hand torch 25'	6	020194	60010	Swirl ring
	059077	07430	Hand torch 50'	7	020203	51120	Tip 40A ϕ 1,0 - .038
		07440	Machine torch 25'		020345	51121	Tip 80A ϕ 1,3 - .052
		07450	Machine torch 50'		020195	51122	Tip 100A ϕ 1,5 - .059
1	020189	07400	Hand torch body (*)	8	020184	60310	Retaining cap
1a		07301	Handgrip with switch	9	020397	51400	Contact tip 80A ϕ 1,3 - .052
1b		07301.20	Switch		020337	51401	Contact tip 100A ϕ 1,5 - .059
2	020201	07410	Machine torch body	10		60340/TD	Contact retaining cap
2a	020245	07215	Machine handle		020336	60340/V/TD	Contact retaining cap Max Life
3	026018	06000.60	O-ring	11	020335	51930/TD	Spacer, hand contact cutting
4		60080	Front insulator	12	020334	51935/TD	Machine shield cap
5	120433	52520/TD	Electrode (replaces 020191)				

THERMAL DYNAMICS® PCH-25/26/28/38® PCH/M-35/40®

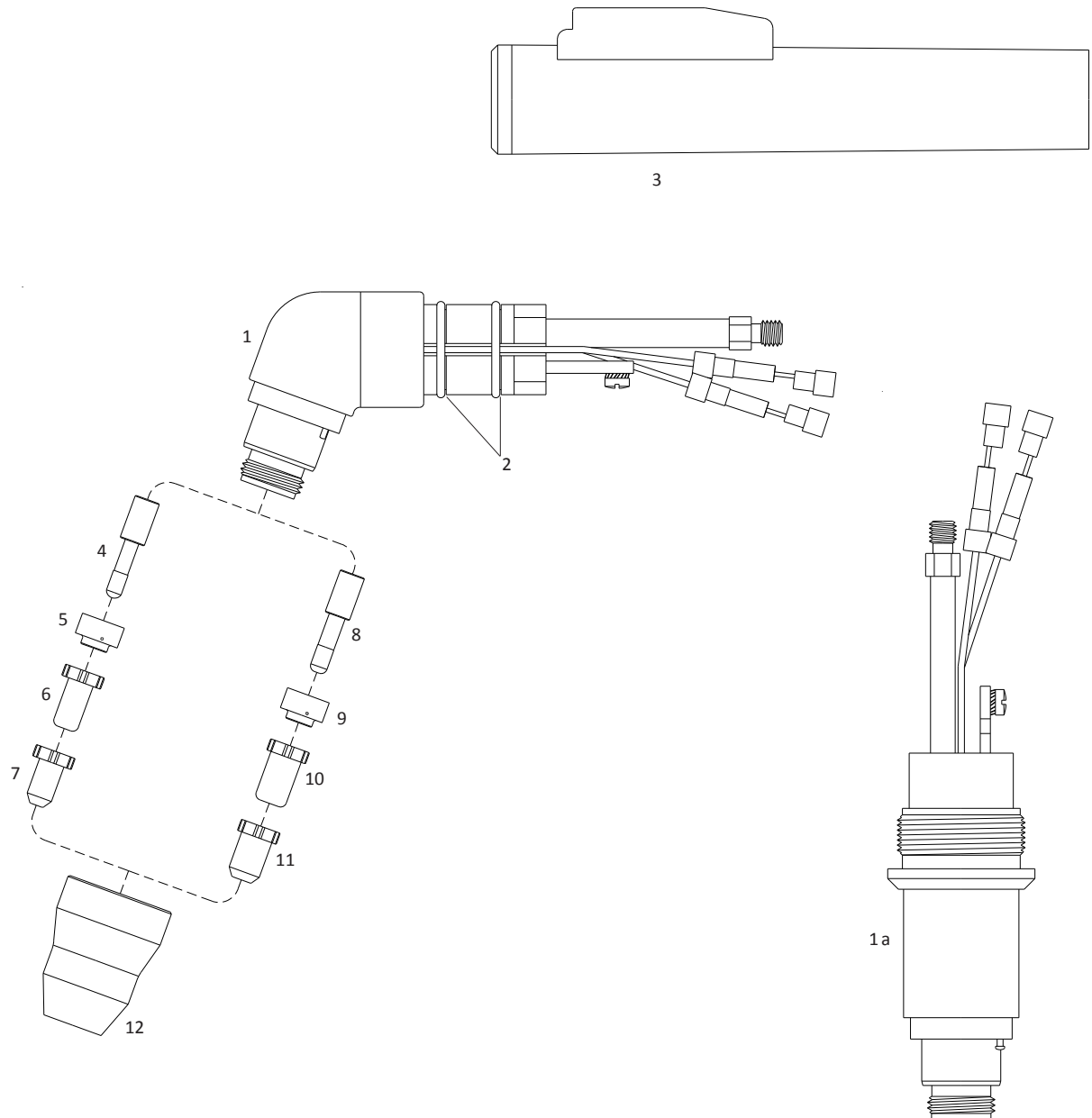

No.	Ref.	Code	Description	No.	Ref.	Code	Description
1	9-8055	07037	70° Torch head	6	9-6002	51292	Tip Gouging Groove Air
	9-5807	07035	70° Torch head	7	9-6001	51291	Tip Drag Cut Air
1a	9-8053	07038	180° Torch head		9-4476	51286	Tip Air
ns	9-7833	07215	Machine handle	8	9-6506	52523/D	Electrode Long Life
2	8-0533	07100.53	O-Ring		9-6506	52523	Electrode Long Life OEM style
3		07103	Handgrip with microswitch	9	9-6507	60051	Gas distributor Long Life
4	9-6006	52519/D	Electrode	10	9-6500	51288	Tip - Standoff Long Life
	9-6006	52519	Electrode OEM style	11	9-6501	51289	Tip - Drag Long Life
5	9-6007	60050	Gas distributor	12	9-6003	60347	Shield cap
6	9-6000	51290	Tip 35A Air				

THERMAL DYNAMICS®

PCH/M-60/75/76/80®

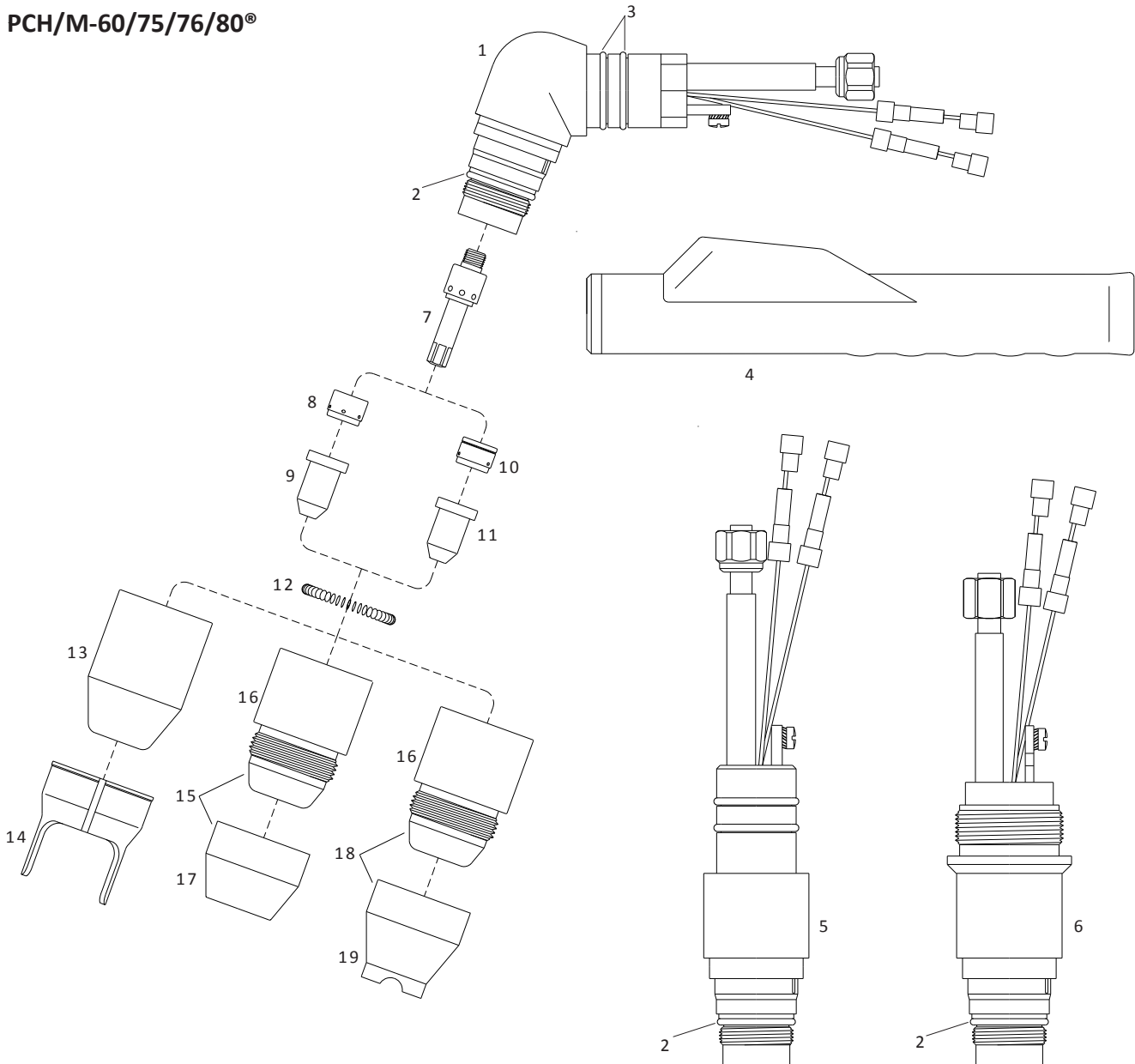

No.	Ref.	Code	Description	No.	Ref.	Code	Description
1	9-8075	07077	70° Torch head	9	9-7726	51297.13	Tip ø 1.24 - .049 60A
	8-7510	07075	70° Torch head		8-7505	51298	Tip ø 1.32 - .052 70A
2	8-0532	07300.60	O-Ring (shield cap)		9-7728	51298.14	Tip ø 1.39 - .055 80A
3	8-0533	07100.53	O-Ring (handle)	10	8-7508	60056	Gas distributor gouging
4		07106	Handgrip with microswitch	11	8-7506	51299	Tip gouging ø 1.86 - .073
5	9-8073	07078	180° Torch head	12	9-7501E	60442	Coil spring
ns	9-7833	07215	Machine handle	13	8-7500	60440	Shield cap
6	8-7512	07076	180° Torch head	14	8-7575	60444	Double pointed spacer
ns	9-5637E	07115	Machine handle	15	8-7496	60446	Shield cap Maximum Life
7	8-7502	52526/D	Electrode	16	8-7498	60441	Shield cap body
8	8-7501	60055	Gas distributor	17	8-7497	60447	Heat shield (copper)
9	8-7503	51296	Tip ø 0.99 - .039 35A	18	8-7507	60445	Crown shield cap assembly
	8-7504	51297	Tip ø 1.17 - .046 55A	19	8-7499	60443	Crown shield cap copper

THERMAL DYNAMICS®

PCH/M-51®

4Xi, 6Xi

**Pak-3XR, Pak-5XR, Pak-5XT,
Pak-6XR, Pak-7XR, Pak-625XR,
Pak-750XR**

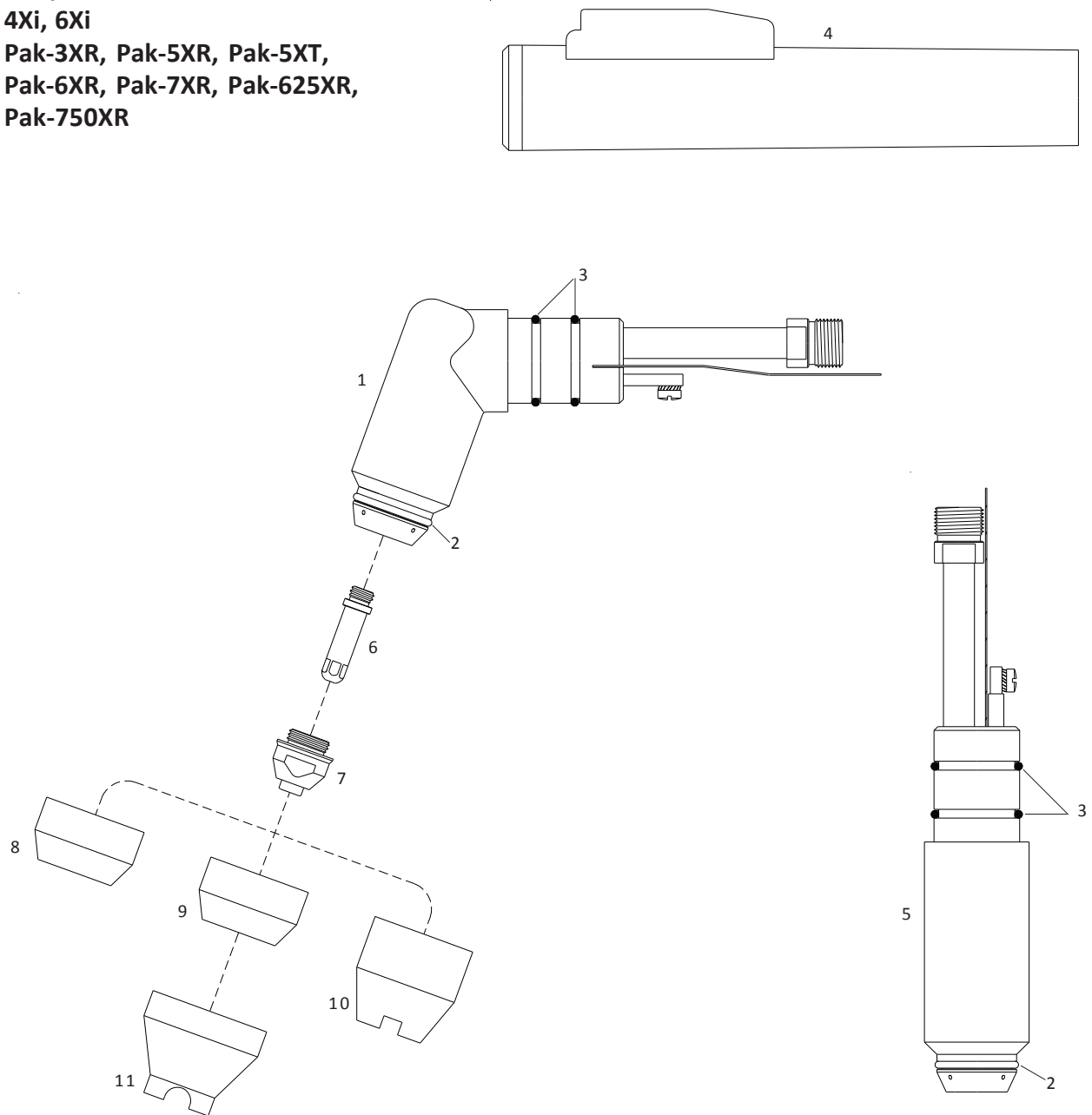

No.	Ref.	Code	Description	No.	Ref.	Code	Description
	2-2860	07120	Hand torch 25' , 7.5m	7	9-5718	51117	Tip \varnothing 0.96 - .038 10/40A
	2-2861	07130	Hand torch 50' , 15m		9-5631	51115	Tip \varnothing 1.10 - .043 10/60A
1	9-5635	07100	70° Torch head		8-3321	51115.12	Tip \varnothing 1.20 - .047 65A
2	8-5525	02000.60	O-Ring (shield cap)		9-5724	51116	Tip gouging \varnothing 2 - .078
3	8-0533	07100.53	O-Ring (handle)	8	9-5630	80010	Shield cap Ceramic
4		07103	Handgrip with microswitch	9	8-2159	60416	Shield cap Phenolic std.
5	9-5634	07110	180° Torch head	10	8-5526	80011	Shield cap Crown Ceramic
6	9-5633	52517	Electrode	11	9-5779	60341	Shield cap Crown

Tec.Mo. srl is in no way affiliated or connected with any of the manufacturers referred to in this catalogue. The parts advertised for sale are not genuine parts, but are parts made for and by Tec.Mo.srl. The use of original equipment manufacturer's part numbers and/or any manufacture's registered or unregistered trade marks are for your convenience only.

THERMAL DYNAMICS®**PCH/M-52®**

**Pak-5XR*, Pak-6XR*, Pak-7XR,
Pak-8XR, Pak-10XR,
Pak-625XR*, Pak-750XR*
Pak-1000XR, Pak-1250XR**

*** DUAL GAS**

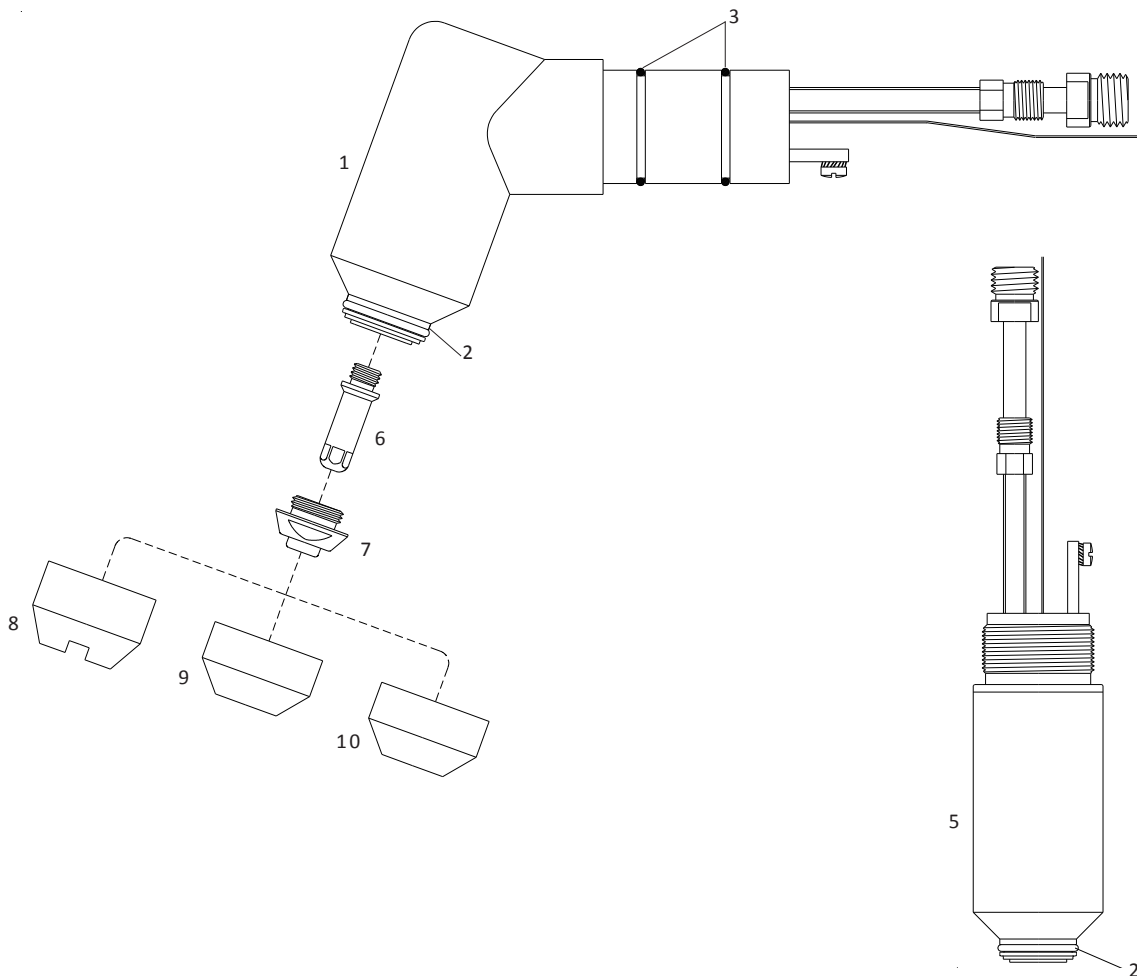
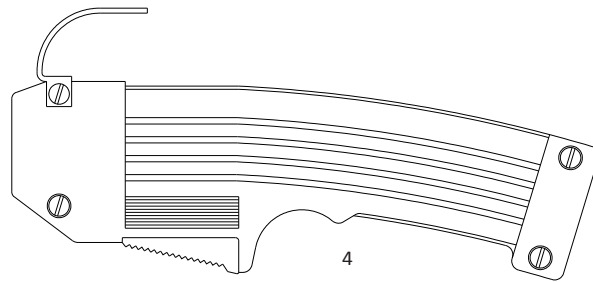

No.	Ref.	Code	Description	No.	Ref.	Code	Description
	2-2936	07220	Hand torch 25', 7.5m	7	9-5702	51180	Tip \varnothing 0.90-.035 35A
	2-2937	07230	Hand torch 50', 15m		9-5618	51181	Tip \varnothing 1.10-.043 45/55A
1	9-5642	07200	70° Torch head		9-5707	51185	Tip \varnothing 1.20-.047 60/70A
2	8-5525	02000.60	O-Ring (shield cap)		9-5782	51185.13	Tip \varnothing 1.32-.052 80A
3	8-0536	07200.50	O-Ring (handle)		9-5708	51186	Tip \varnothing 1.50-.059 105A
4	9-5644E	07307	Handgrip with microswitch	8	9-5694	80017	Shield cap Crown Ceramic
5	9-5643	07210	180° Torch head	9	9-5781	60418	Shield cap Phenolic std.
6	8-3331	52565	Electrode Air	10	9-5617	80015	Shield cap Ceramic std.
	9-5619	52565/N	Electrode Air Plated				

EUROLOK™ PCH-102TL® 30-100A

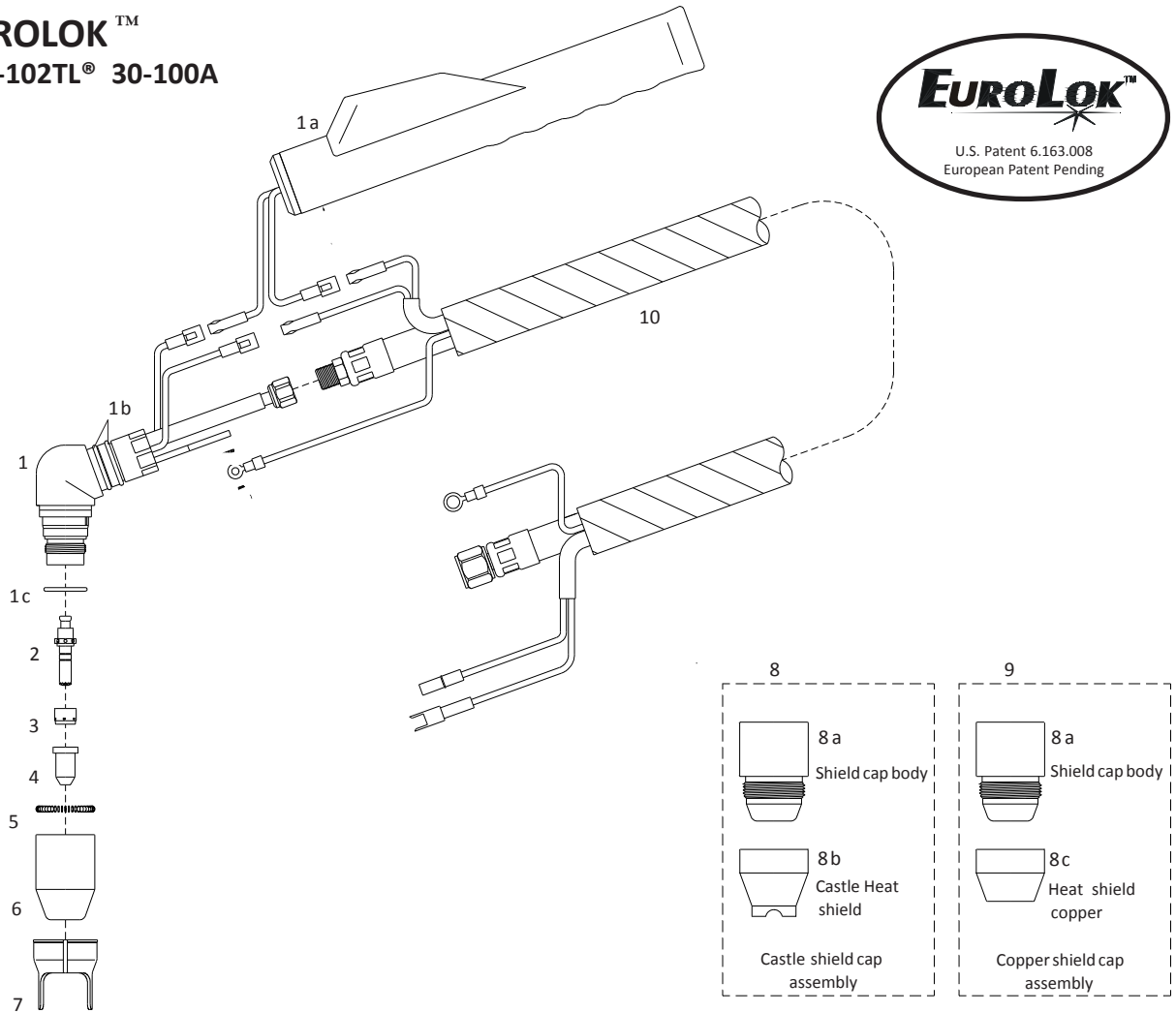
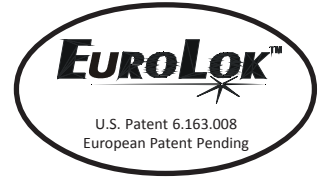

No.	Ref.	Code	Description	No.	Ref.	Code	Description
1	9-8405EL	07902	Hand torch head	4	8-7506	51299	Tip gouging, Air/N2 ϕ 1.86 - 0.073
1a		07106E	Handle with microswitch	5	9-7501E	60442	Coil spring
1b	8-0533	07100.53	O-Ring	6	8-7500E	60440	Shield cap (including item #5)
1c	8-0532	07300.60	O-Ring	7	8-7575	60444	Double pointed spacer
2	9-8402EL	52527	Electrode Air/N2	8	8-7507E	60445	Castle shield cap assembly (including item #5, 8a, 8b)
3	8-7501EL	60055/EL	Gas Distributor cutting	8a	8-7498E	60441	Shield cap body (including item #5)
	8-7508EL	60056/EL	Gas Distributor gouging	8b	8-7499	60443	Castle Heat shield (copper)
4	9-8406	51298.15	Tip 100A cutting, Air/N2 ϕ 1.50 - 0.059	8c	8-7497	60447	Heat shield (copper)
	9-7728	51298.14	Tip 80A cutting, Air/N2 ϕ 1.39 - 0.055	9	8-7496E	60446	Copper shield cap assembly (including item # 5, 8a, 8c)
	8-7505	51298	Tip 70A cutting, Air/N2 ϕ 1.32 - 0.052		07062TL		Hand torch, 6m - 20'
	9-7726	51297.13	Tip 60A cutting, Air/N2 ϕ 1.24 - 0.049		07072TL		Hand torch, 12m - 40'
	8-7504	51297	Tip 50A cutting, Air/N2 ϕ 1.17 - 0.046	10		07064TL	Lead assembly, 6m - 20'
	8-7503	51296	Tip 30/40A cutting, Air/N2 ϕ 0.99 - 0.039			07074TL	Lead assembly, 12m - 40'

EUROLOK™
PCM-102TL® 30-100A

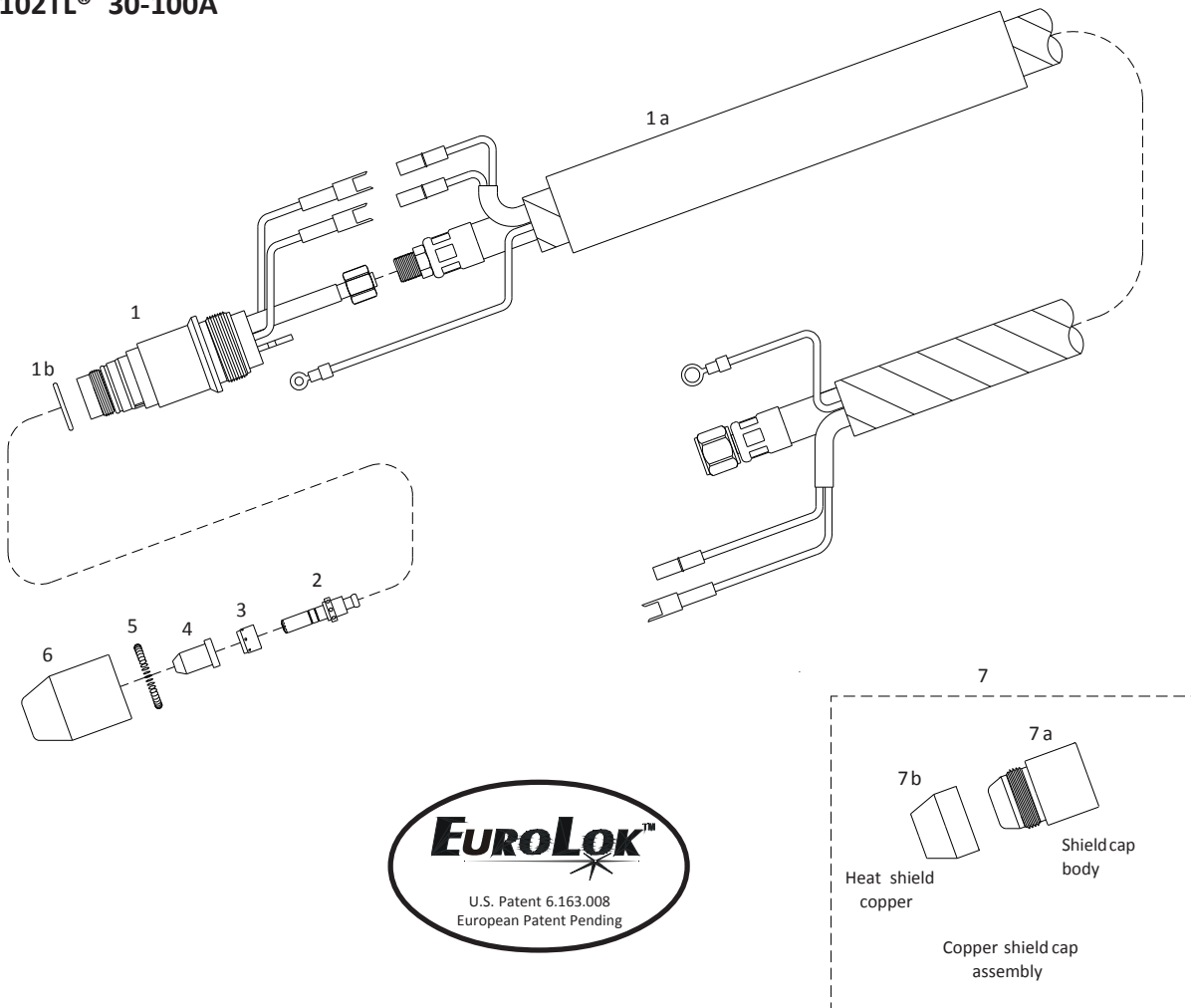

No.	Ref.	Code	Description	No.	Ref.	Code	Description
1	9-8403EL	07903	Machine torch head	5	9-7501E	60442	Coil spring
1a	8-0532	07300.60	O-Ring	6	8-7500E	60440	Shield cap (including item #5)
1b		07215	Fiberglass positioning tube	7	8-7496E	60446	Copper shield cap assembly (including item # 5, 7a, 7b)
2	9-8402EL	52527	Electrode Air/N2	7a	8-7498E	60441	Shield cap body (including item #5)
3	8-7501EL	60055/EL	Gas Distributor cutting	7b	8-7497	60447	Heat shield (copper)
	8-7508EL	60056/EL	Gas Distributor gouging			07082TL	Machine torch, 6m - 20'
4	9-8406	51298.15	Tip 100A cutting, Air/N2 ϕ 1.50 - 0.059			07092TL	Machine torch, 12m - 40'
	9-7728	51298.14	Tip 80A cutting, Air/N2 ϕ 1.39 - 0.055			07084TL	Lead assembly, 6m - 20'
	8-7505	51298	Tip 70A cutting, Air/N2 ϕ 1.32 - 0.052			07094TL	Lead assembly, 12m - 40'
	9-7726	51297.13	Tip 60A cutting, Air/N2 ϕ 1.24 - 0.049				
	8-7504	51297	Tip 50A cutting, Air/N2 ϕ 1.17 - 0.046				
	8-7503	51296	Tip 30/40A cutting, Air/N2 ϕ 0.99 - 0.039				
	8-7506	51299	Tip gouging, Air/N2 ϕ 1.86 - 0.073				

UNITORCH™ EL-120™ 30-120A

With & without HIGH FREQUENCY

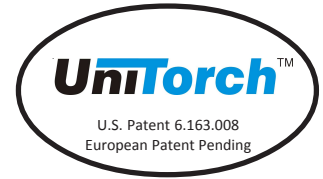
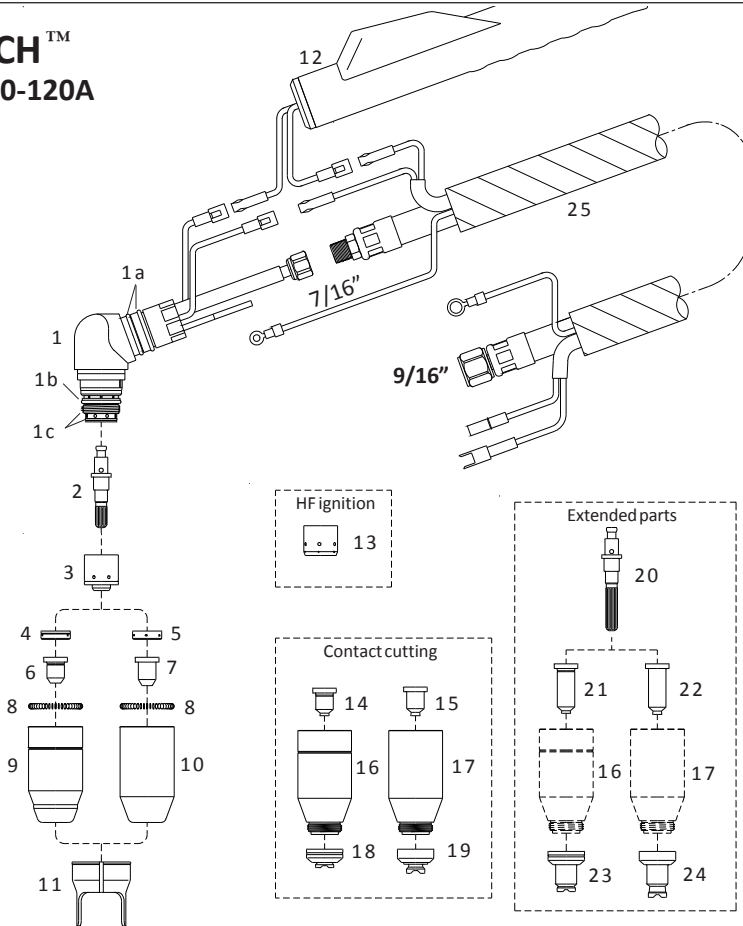
**Torches are supplied with
Non-High Frequency parts**

No.	Code	Description	No.	Code	Description
1	07920	Torch head	15	51484	Contact tip Air/N2 60A
1a	07100.53	O-Ring		51485	Contact tip Air/N2 70A
1b	07300.60	O-Ring		51486	Contact tip Air/N2 80A
1c	07920.60	O-Ring		51487	Contact tip Air/N2 90/100A
2	52600	Electrode, Air/N2		51488	Contact tip Air/N2 120A
3	07923	Start cartridge 30/120A	16	60482	Shield cap body 30/60A
4	60060	Gas distributor 30/60A		60482/S	Shield cap body Max Life 30/60A
5	60061	Gas distributor 60/120A	17	60483	Shield cap body 60/120A
6	51470	Tip cutting Air/N2 30A		60483/S	Shield cap body Max Life 60/120A
	51471	Tip cutting Air/N2 40A	18	60485	Shield cap hand 30/60A
	51472	Tip cutting Air/N2 50/60A	19	60486	Shield cap hand 60/120A
7	51474	Tip cutting Air/N2 60A	20	52603	Extended electrode Air/N2
	51475	Tip cutting Air/N2 70A	21	51490	Extended contact tip Air/N2 30A
	51476	Tip cutting Air/N2 80A		51491	Extended contact tip Air/N2 40A
	51477	Tip cutting Air/N2 90/100A		51492	Extended contact tip Air/N2 50/60A
	51478	Tip cutting Air/N2 120A	22	51493	Extended contact tip Air/N2 60A
8	60442	Coil spring		51494	Extended contact tip Air/N2 70A
9	60480	Shield cap 30/60A		51495	Extended contact tip Air/N2 80A
	60480/S	Shield cap Max Life 30/60A		51496	Extended contact tip Air/N2 90/100A
10	60481	Shield cap 60/120A		51497	Extended contact tip Air/N2 120A
	60481/S	Shield cap Max Life 60/120A	23	60490	Extended shield cap Hand 30/60A
11	60444	Double pointed spacer	24	60491	Extended shield cap Hand 60/120A
12	07106E	Handle with microswitch		09000	Hand torch, 6m - 20'
13	07924	Insulator High Frequency 30/120A		09010	Hand torch, 12m - 40'
14	51480	Contact tip Air/N2 30A	25	09080	Lead assembly 6m - 20'
	51481	Contact tip Air/N2 40A		09085	Lead assembly 12m - 40'
	51482	Contact tip Air/N2 50/60A			

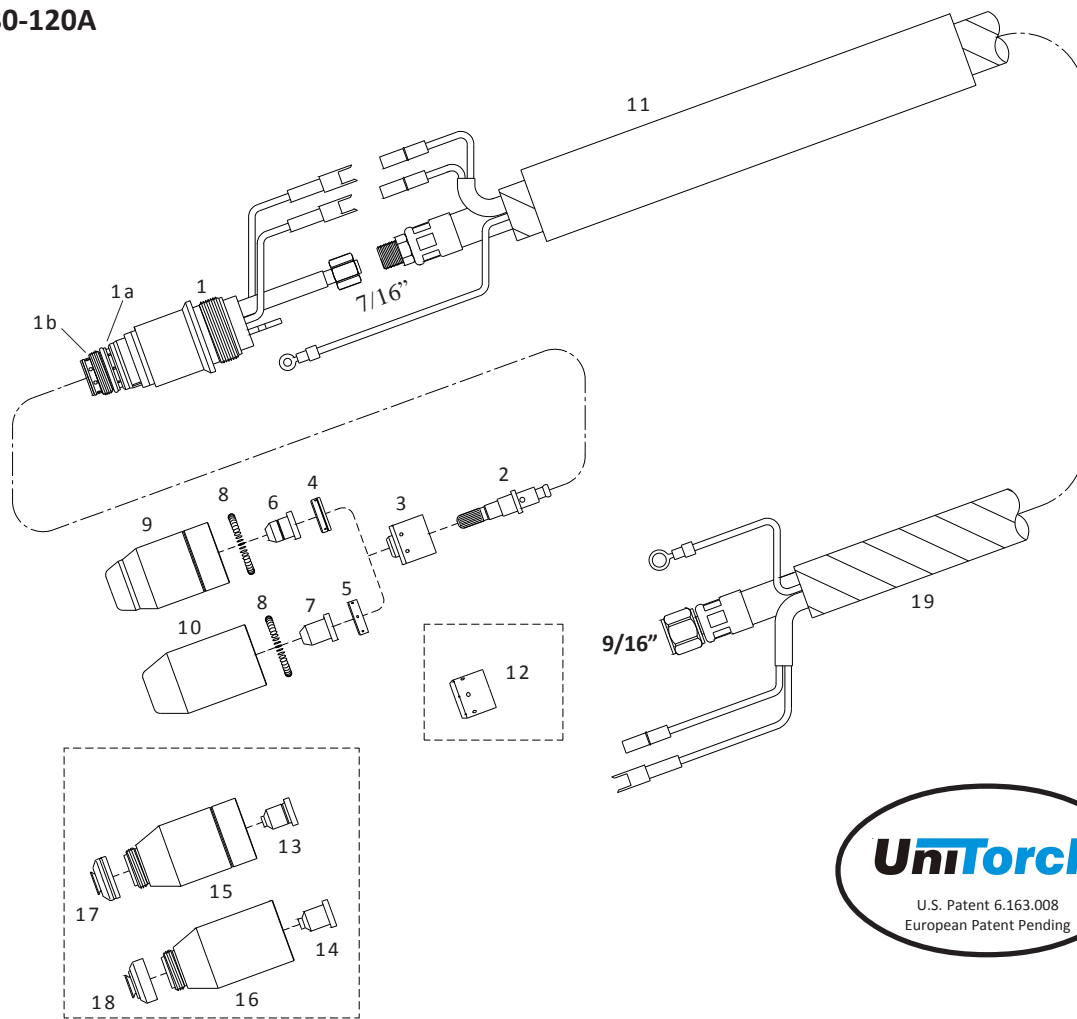
UNITORCH™
EL-120™ 30-120A

Torches are supplied with Non-High Frequency parts

No.	Code	Description	No.	Code	Description
1	07921	Torch head	11	07215	Fiberglass positioning tube
1a	07300.60	O-Ring	12	07924	Insulator High Frequency 30/120A
1b	07920.60	O-Ring	13	51480	Contact tip Air/N2 30A
2	52600	Electrode, Air/N2		51481	Contact tip Air/N2 40A
3	07923	Start cartridge 30/120A		51482	Contact tip Air/N2 50/60A
4	60060	Gas distributor 30/60A	14	51484	Contact tip Air/N2 60A
5	60061	Gas distributor 60/120A		51485	Contact tip Air/N2 70A
6	51470	Tip cutting Air/N2 30A		51486	Contact tip Air/N2 80A
	51471	Tip cutting Air/N2 40A		51487	Contact tip Air/N2 90/100A
	51472	Tip cutting Air/N2 50/60A		51488	Contact tip Air/N2 120A
7	51474	Tip cutting Air/N2 60A	15	60482	Shield cap body 30/60A
	51475	Tip cutting Air/N2 70A		60482/S	Shield cap body 30/60A Max Life
	51476	Tip cutting Air/N2 80A	16	60483	Shield cap body 60/120A
	51477	Tip cutting Air/N2 90/100A		60483/S	Shield cap body 60/120A Max Life
	51478	Tip cutting Air/N2 120A	17	60487	Shield cap machine 30/60A
8	60442	Coil spring	18	60488	Shield cap machine 60/120A
9	60480	Shield cap 30/60A		09020	Machine torch, 6m - 20'
	60480/S	Shield cap 30/60A Max Life		09030	Machine torch, 12m - 40'
10	60481	Shield cap 60/120A	19	09090	Lead assembly 6m - 20'
	60481/S	Shield cap 60/120A Max Life		09095	Lead assembly 12m - 40'

KJELLBERG®

PA-S47CNC® - FineFocus 450®

PB-S20W/WH® PB-S25W/WH®

PB-S40W/WH® PB-S45W/WH®

PB-S45W/WH-1®

PZ-S45W®

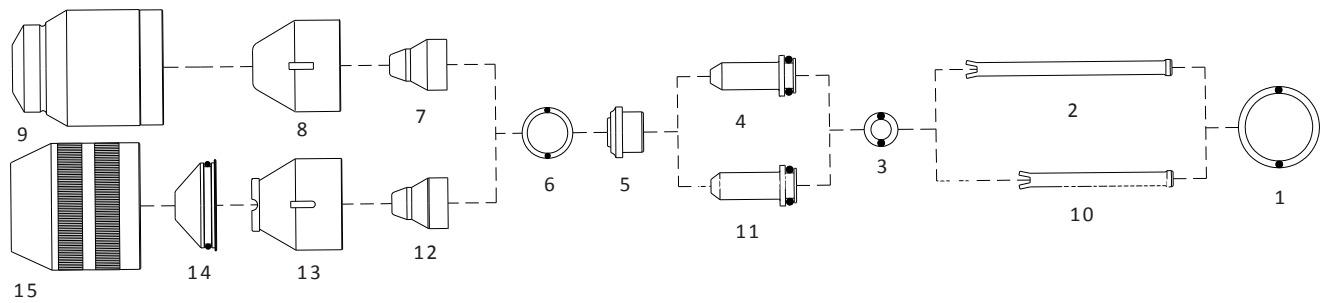

No.	Ref.	Code	Description	Pkg.	No.	Ref.	Code	Description	Pkg.
1	.10.575.052	60365.41	O-Ring Silicone	20	10	.11.828.001.152	60366	Cooling tube	1
2	.11.832.201.152	60366B	Cooling tube W901	1	11	.11.834.321.3001	52708AG	Electrode Kb - XI Silver	5
3	.10.505.827	20705.40	O-Ring Silicone	20	12	.11.834.321.410	51656.10	Nozzle Lle - XI ø 1.0, O ₂	5
4	.11.828.001.3001	52705	Electrode Kb, Air, XF	5		.11.834.321.413	51657.13	Nozzle Lde - XI ø 1.3, O ₂	5
5	.11.828.001.153	60066	Swirl ring Max Life Z111	2		.11.834.321.414	51657.14	Nozzle Lee - XI ø 1.4, O ₂	5
6	.10.575.036	60066.41	O-Ring Silicone	20	13	.11.832.201.160	60570	Retaining cap W3030	1
7	.11.828.203.410	51594	Nozzle Lle ø 1.0 - Air	5	14	.11.832.201.1571	60562	Shield ø 4.0 W4140	5
	.11.828.203.413	51595	Nozzle Lde ø 1.3 - Air	5		.11.832.201.1561	60562.30	Shield ø 3.0 W4130	5
	.11.828.203.414	51596	Nozzle Lee ø 1.4 - Air	5	15	.11.832.201.081	60560	Shield cap W501	5
8	.11.830.301.151	60357	Retaining cap ø 9.6	5					
9	.11.828.101.160	60359	Shield cap	1					

Notes

ESAB® L-TEC® PT-20®

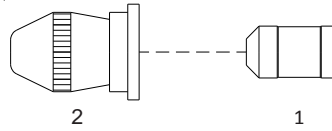

No.	Ref.	Code	Description	No.	Ref.	Code	Description
1	21150	52884	Electrode	2	21329	51346	Tip \varnothing 1.3 - .051 70A
2	21330	51345	Tip \varnothing 1.0 - .039 50A		21328	51347	Tip \varnothing 1.5 - .059 100A

ESAB® L-TEC® PT-23/27®

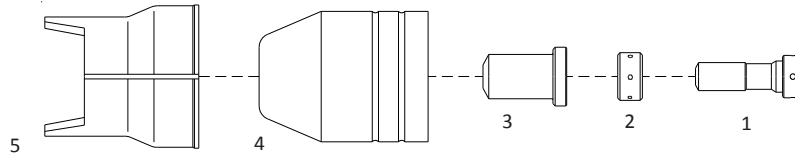

No.	Ref.	Code	Description	No.	Ref.	Code	Description
1	33366	52882	Electrode	3	33418	51342/TD	Tip \varnothing 1.32 - .052 80A
2	33367	80005	Swirl Baffle	4	21616	60460	Shield cap (PT 27)
3	33368	51340/TD	Tip \varnothing 0.93 - .037 30A	5	21420	60461	Double pointed spacer
	33369	51341/TD	Tip \varnothing 1.16 - .046 50A				

ESAB® L-TEC® PT-31® PT-31XL®

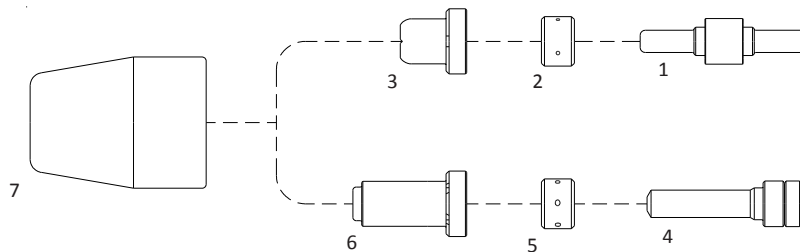

No.	Ref.	Code	Description	No.	Ref.	Code	Description
1	18205	52057	Electrode	6	20860	51335/TD	Tip \varnothing 0.96 - .038 30A
2	18785	80002	Swirl Baffle 4 holes		21008	51336/TD	Tip \varnothing 1.07 - .042 40A
3	18866	51165	Tip - 4 stakes - \varnothing 1.0 - .039 30A		20861	51337/TD	Tip \varnothing 1.17 - .046 50A
4	20862	52881	Electrode	7	18204	80001	Shield cap
5	20463	80003	Swirl Baffle 6 holes				

ESAB® L-TEC® PT-32®

ON REQUEST

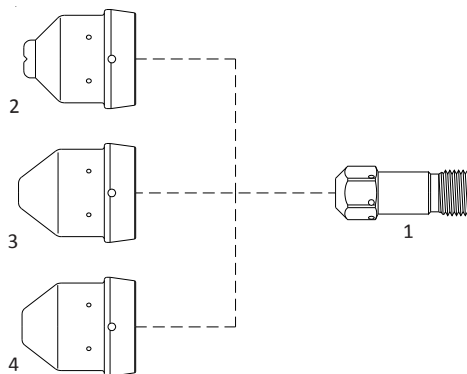

No.	Ref.	Code	Description	No.	Ref.	Code	Description
1	0558001969	52562	Electrode	3	0558002618	51536	Tip 50-70A
2	0558002908	51535	Tip (drag) 40A	4	0558002837	51537	Tip 90A

**MILLER®
ICE-25C®
Spectrum®375**

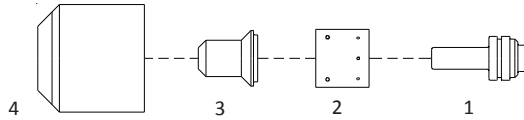

No.	Ref.	Code	Description	No.	Ref.	Code	Description
1	176655	52631	Electrode	3	176656	51431	Tip \varnothing 0.75 - .030
2	176657	60036	Swirl Ring	4	176658	60300	Retaining cap

**MILLER®
ICE-27C®
Spectrum®375 CutMate®**

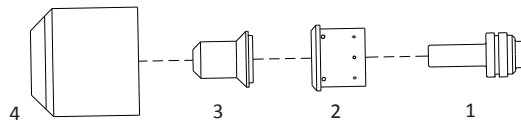

No.	Ref.	Code	Description	No.	Ref.	Code	Description
1	176655	52631	Electrode	3	176656	51431	Tip \varnothing 0.75 - .030
2	202809	60038	Swirl Ring	4	202808	60300	Retaining cap

**MILLER®
ICE-50C®
Spectrum®701**

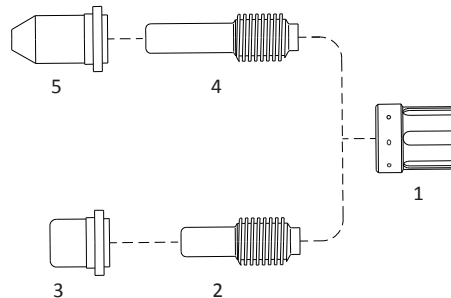

No.	Ref.	Code	Description	No.	Ref.	Code	Description
1	177886	60046	Swirl Ring	4	180340	52635	Extended electrode
2	177875	52634	Electrode	5	177876	51435	Extended tip
3	177890	51433	Tip				

**MILLER®
ICE-55C® / ICE-55CM®
Spectrum®625
Spectrum®2050**

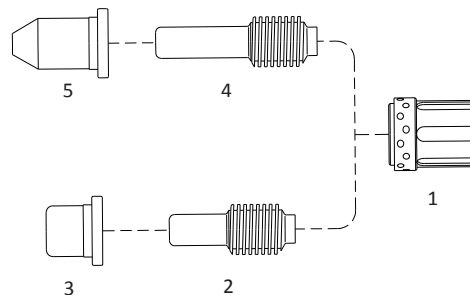

No.	Ref.	Code	Description	No.	Ref.	Code	Description
1	192049	60047	Swirl Ring	4	192048	52635	Extended electrode (replaces 180340)
2	192047	52634	Electrode (replaces 177875)	5	192056	51436	Extended tip 55A
3	192051	51434	Tip		192052	51437	Extended tip 35A

MILLER® APT 5000/7000®
OTC® D-7000 - A50/A70®

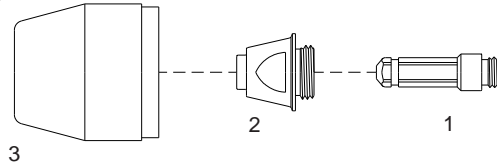

No.	Ref.	Code	Description	No.	Ref.	Code	Description
OTC® D-7000 - A50/A70®				MILLER® APT 5000/7000®			
1	H669G11	52740	Electrode	1	123-899	52740	Electrode
2	H669G06	51255	Tip S 50A	2	123-898	51255	Tip ø 1.0 50A
	H669G05	51256	Tip H 70A		134-338	51256	Tip ø 1.2 70A
3	H669G04	80056	Shield cap D - 7000	3	123-897	80056	Shield cap (APT 5000)
		80058	Shield cap A50/A70				

OTC®
D - 12000

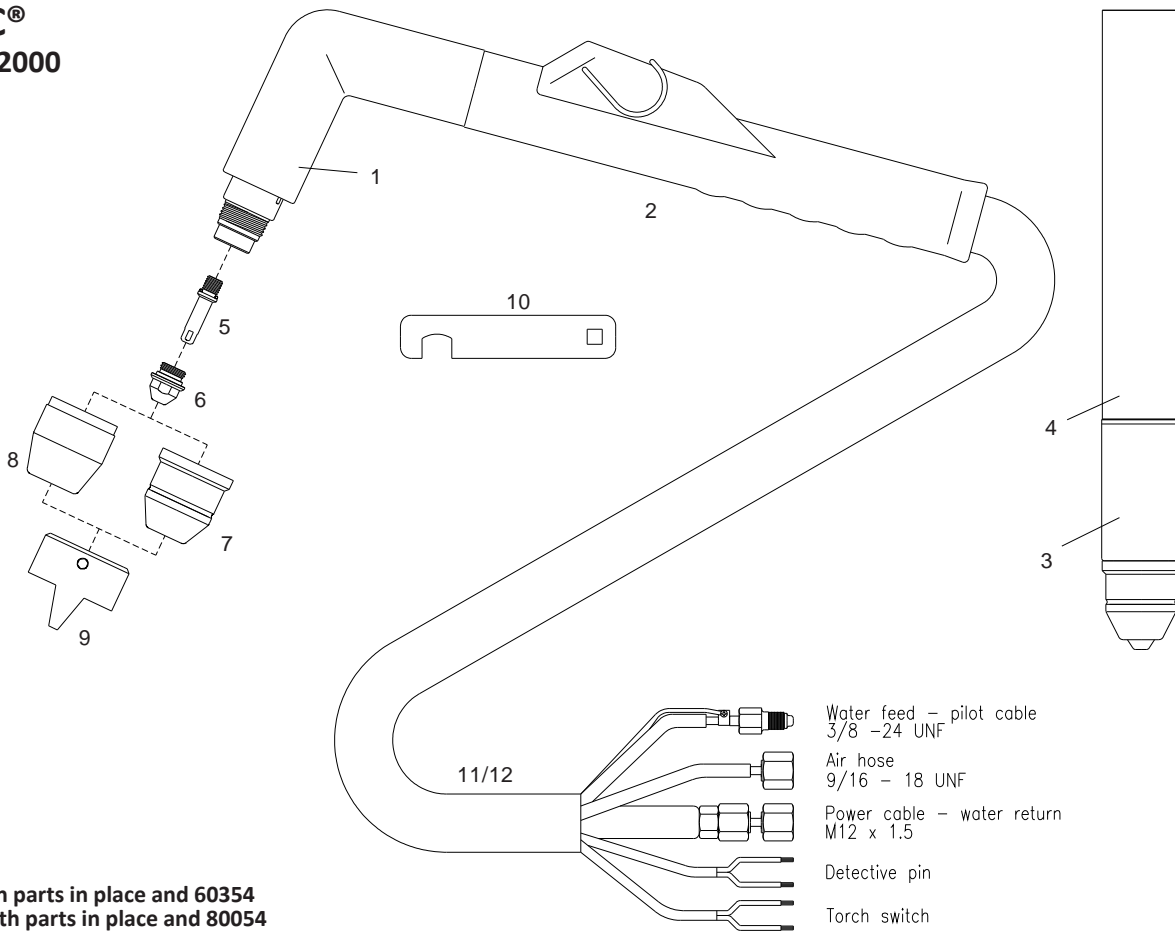

(*) with parts in place and 60354
(**) with parts in place and 80054

No.	Ref.	Code	Description	Pkg.	No.	Ref.	Code	Description	Pkg.
		07820	Hand torch 6m	1	6	H839K01	51271	Tip ø 1.3 80A	10
		07830	Hand torch 12m	1		H839G03	51272	Tip ø 1.6 120A	10
		07840	Machine torch 6m	1	7		80054	Shield cap Ceramic	10
		07850	Machine torch 12m	1			60354	Shield cap Fiberglass	10
1		07801	Hand torch head (*) w/handle	1	8	H839G02	80057	Shield cap (genuine torch head only)	10
2		04280/C	Handgrip w/microswitch	1	9		60374	Double pointed spacer	6
3		07811	Machine torch head (**) w/handle	1	10		07800.57	Wrench for tip & electrode	1
4		07215	Machine handle	1	11		07880	Cable 6m Hand torch	1
5	H839M00	52750/OR	Electrode with O-Ring	10			07885	Cable 12m Hand torch	1
6	H839K03	51269	Tip ø 0.8 30A	10	12		07890	Cable 6m Machine torch	1
	H839K02	51270	Tip ø 1.0 50A	10			07895	Cable 12m Machine torch	1

SAF® - FRO® CP-40 R - CP-100R®

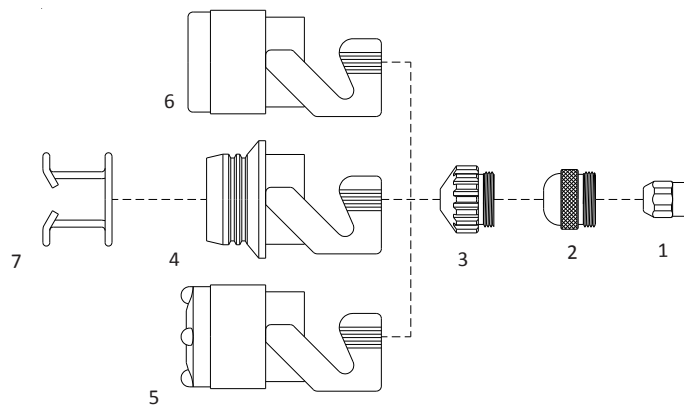

No.	Ref.	Code	Description	No.	Ref.	Code	Description
1	0408-2051	52014	Electrode Zr.	3	0408-2385	51118	Tip ø 1.6
	0408-2404	52514	Electrode Hf.	4	0408-2267	60426	TN Protection nozzle guide
2	0408-2052	51103	Tip 20/40	5	0408-2405	60427	TI Ceramic assembly with bosses
3	0408-2261	51104	Tip ø 1.0	6	0408-2268	60428	TI Ceramic guide
	0408-2262	51105	Tip ø 1.2	7	0408-2053	51901	Spacer spring

PANASONIC®

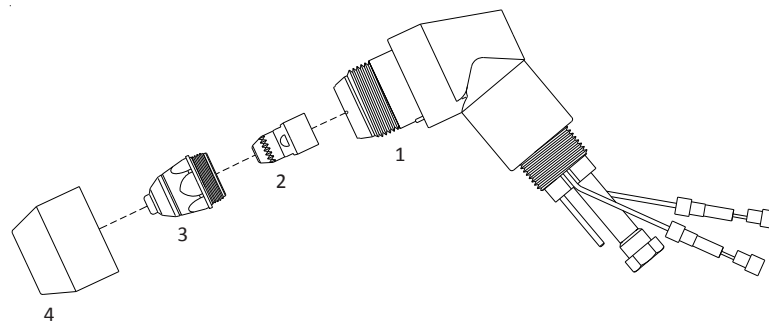

No.	Ref.	Code	Description	No.	Ref.	Code	Description
1	TKU08103	08000	Hand torch head	3	TET01130	51280.13	Tip ø 1.3 60A
2	TET02033	52790	Electrode		TET01512	51280.15	Tip ø 1.5 80A
3	TET01110	51280.10	Tip ø 1.0 40A	4	TGN02004	80045	Shield cap

SMITH® - MERKLE®

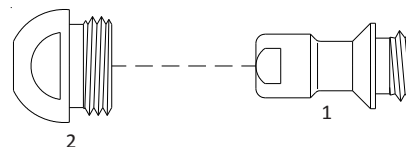

No.	Ref.	Code	Description	No.	Ref.	Code	Description
1	30808-5	52715	Electrode	2	30814-5	51572	Tip ø 1,4
2	30812-5	51570	Tip ø 1,0		30815-5	51573	Tip ø 1,6
	30813-5	51571	Tip ø 1,2		30344-5	51574	Tip ø 1,8

AUTOGEN RITTER® PHB 120

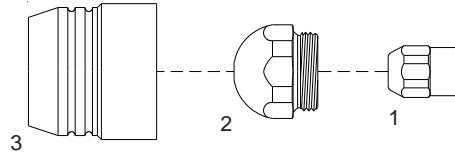

No.	Ref.	Code	Description	No.	Ref.	Code	Description
1	412-02-00	52875	Electrode	2	412-04-14	51667	Tip \varnothing 1.4
2	412-04-10	51665	Tip \varnothing 1.0		412-04-16	51668	Tip \varnothing 1.6
	412-04-12	51666	Tip \varnothing 1.2	3	413-05-00	60430	Nozzle cap w/inbuilt safety

BINZEL® PSB 31 KK®

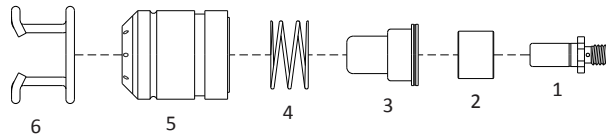

No.	Ref.	Code	Description	No.	Ref.	Code	Description
1	742.0016	52018	Electrode mm 15.5	3	742.0106	41006	Tip \varnothing 1.2
	742.0017	52016	Electrode mm 16	4	742.0084	51906	Spring
	742.0018	52017	Electrode mm 16.5	5		60408	Air diffuser, insulator
2	742.0082	60407	Insulating sleeve		742.0086	60409	Air diffuser with safety ring
3	742.0083	41005	Tip \varnothing 1.0	6	742.0089	51902	Spacer spring

BINZEL® PSB 60/80/121®

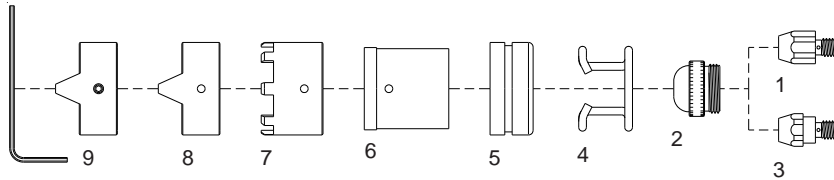

No.	Ref.	Code	Description	No.	Ref.	Code	Description
1	743.0077	52008	Electrode Zr.	3	743.0425Hf	52655	Special electrode Hf.
	743.0067	52515	Electrode Hf.	4	743.0149	51901	Spacer spring
2	743.0122	51107	Tip \varnothing 1.0	5	743.0125	60410	Distance sleeve
	743.0143	51108	Tip \varnothing 1.3	6	743.0126	60411	Distance nozzle support
	743.0132	51109	Tip \varnothing 1.5	7	743.0127	60361	Crown spacer nozzle
	743.0209	51110	Tip \varnothing 1.8	8	743.0168	60360	Double pointed nozzle
	743.0355	51135	Tip \varnothing 2.0	9	743.0267	60362	Double pointed nozzle with screw-key
3	743.0425Zr	52055	Special electrode Zr.				

BINZEL® ABIPLAS CUT 70®

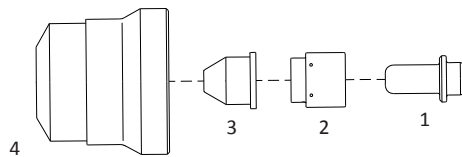

No.	Ref.	Code	Description	No.	Ref.	Code	Description
1	742.D056	52660	Electrode	3	742.D018	51545.11	Conical tip \varnothing 1.1
2	742.D073	60200	Swirl ring		742.D041	51545.12	Conical tip \varnothing 1.2
3	742.D008	51545.09	Conical tip \varnothing 0.9	4	742.D023	60470	Shield cap

BINZEL®
ABIPLAS CUT 110®

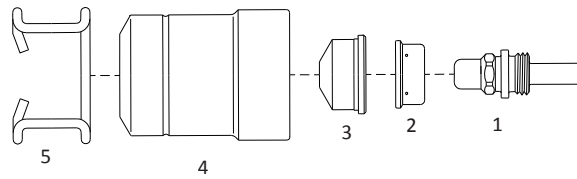

No.	Ref.	Code	Description	No.	Ref.	Code	Description
1	745.D008	52665	Electrode	3	745.D017	51540.14	Tip ø 1.4
2	745.D113	60201	Swirl ring		745.D065	51540.16	Tip ø 1.6
3	745.D018	51540.10	Tip ø 1.0	4	745.D026	60473	Shield cap
	745.D010	51540.12	Tip ø 1.2	5	745.D012	51910	Spacer spring

BINZEL®
ABIPLAS CUT 150®

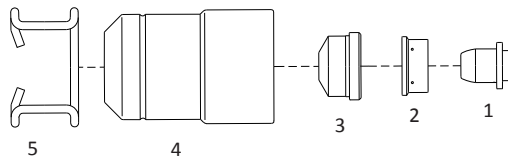

No.	Ref.	Code	Description	No.	Ref.	Code	Description
1	757.D008	52670	Electrode	3	757.D010	51550.16	Tip ø 1.6
2	757.D060	60202	Swirl ring		757.D011	51550.18	Tip ø 1.8
3	757.D037	51550.12	Tip ø 1.2	4	757.D042	60475	Shield cap
	757.D009	51550.15	Tip ø 1.5	5	757.D012	51910	Spacer spring

CEBORA®
CP-40®

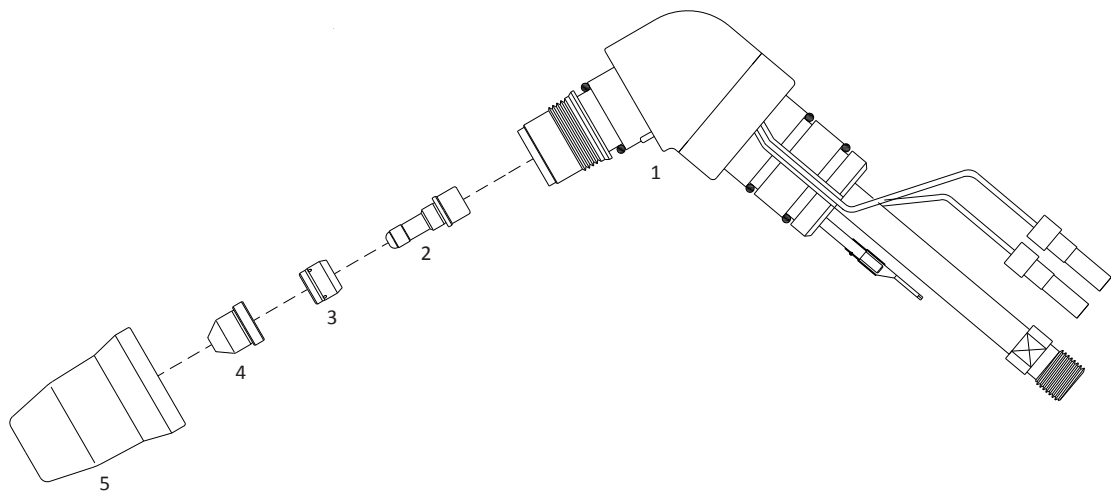

No.	Ref.	Code	Description	No.	Ref.	Code	Description
1	1359	01040	Hand torch head	4	1290	51086	Tip ø 0.7
2	1516	52545	Electrode	5	1906	60323	Retaining cap
3	1507	60007	Swirl ring				

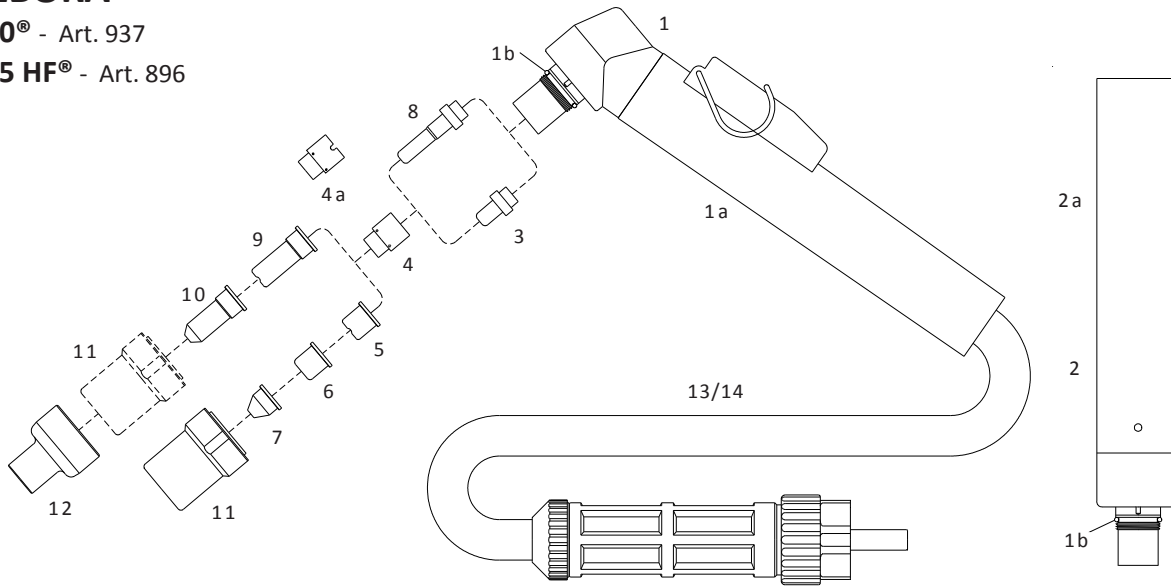
CEBORA®**P50®** - Art. 937**P35 HF®** - Art. 896

No.	Ref.	Code	Description	No.	Ref.	Code	Description
	1526	03050/C	Hand torch, 6m, 1/8" connection	5	1396	51095	Tip Long Life \varnothing 1.0
	1574	03051/C	Hand torch, 6m, central connector			51100/S	Tip Long Life \varnothing 1.1
		03150/C	Hand torch, 12m, 1/8" connection	6		51099	Flat tip \varnothing 1.0
		03151/C	Hand torch, 12m, central connector	7	1305	51098	Conical tip \varnothing 1.0 Low Amp.
		03400	Machine torch, 6m, 1/8" connection	8	1518	52513/L	Extended electrode
		03401	Machine torch, 6m, central connector	9	1370	51102	Extended tip \varnothing 1.0
		03500	Machine torch, 12m, 1/8" connection		1395	51095/L	Extended tip Long Life \varnothing 1.0
		03501	Machine torch, 12m, central connector			51102/S	Extended tip Long Life \varnothing 1.1
1	1352	01000	Hand torch head	10	1306	51101	Extended conical tip \varnothing 1.0
1a	1356	03280/C	Handgrip with microswitch				Low Amperage
1b		01000.60	O-Ring	11	5.710.121	60320	Retaining cap
2		03300	Machine torch head	12		51965	Shield cap, hand, extended tips
2a		03310	Machine handle	13	1344	03240	Cable, 6m, 1/8", Hand torch
3	1521	52512/L	Electrode			03250	Cable, 12m, 1/8", Hand torch
4		60001	Swirl ring	14		03320	Cable, 6m, 1/8", Machine torch
4a	1510	60002	Swirl ring with notches			03330	Cable, 12m, 1/8", Machine torch
5	1304	51100	Tip \varnothing 1.0				

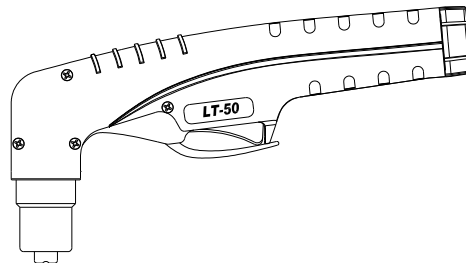
LT-50®Suitable for
CEBORA® P50®**Consumables:**
see **CEBORA® P50®**

Ref.	Code	Description	Ref.	Code	Description
1526	03050LT	Hand torch, 6m, 1/8" connection		01001	Torch head
1574	03051LT	Hand torch, 6m, central connector		01000.60	O-Ring
	03150LT	Hand torch, 12m, 1/8" connection		09606	Handgrip with switch
	03151LT	Hand torch, 12m, central connector		07301.20	Switch
	01001/Kit	Torch head with handle			

CEBORA®

P70® - Art. 941

35 PC/HF® - Art. 292

P36® - Art. 938

P52® - Art. 940

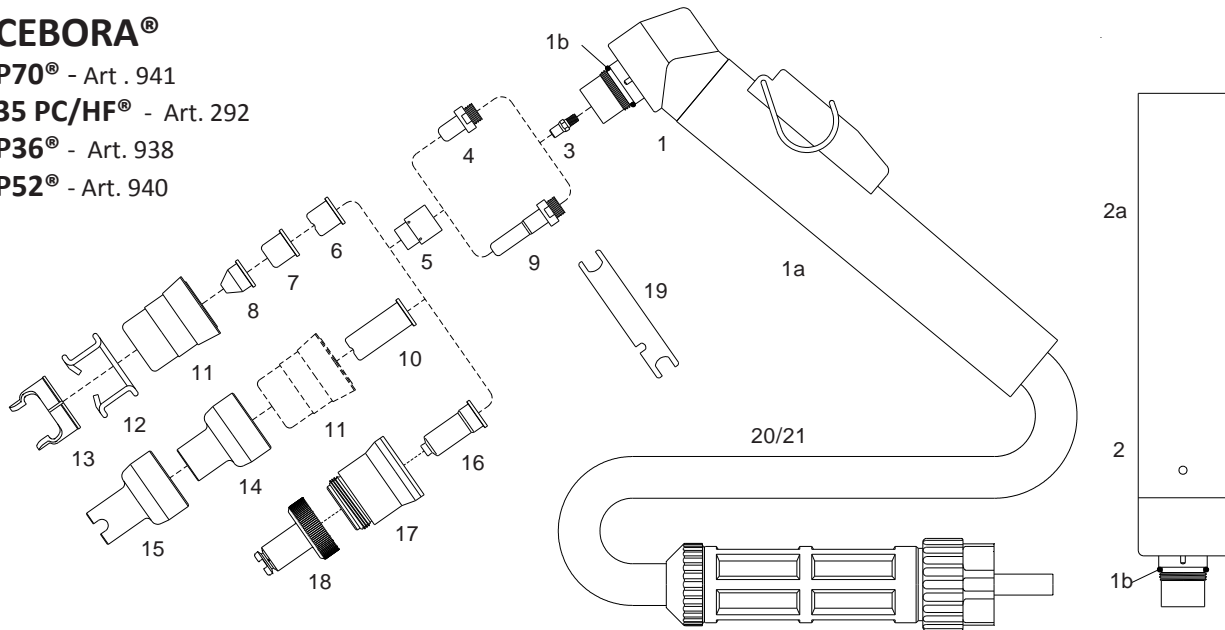

No.	Ref.	Code	Description	No.	Ref.	Code	Description
	1564	03070/CS	Hand torch, 6m, 1/8" connection	8		51098.12	Conical tip \varnothing 1.2
	1573	03071/CS	Hand torch, 6m, central connector	9	1368	52553	Extended electrode
	1573.20	03171/CS	Hand torch, 12m, central connector	10	1366	51102.09	Extended tip \varnothing 0.9 35A
	1563	03470/S	Machine torch, 6m, 1/8" connection		1395	51095/L	Extended tip Long Life \varnothing 1.0 50A
	1566	03471/S	Machine torch, 6m, central connector			51102/S	Extended tip Long Life \varnothing 1.1 60A
	1566.20	03571/S	Machine torch, 12m, central connector			51096/L	Extended tip Long Life \varnothing 1.2 70A
1	1351	01070	Hand torch head	11	5.710.171	60321	Retaining cap
1a	1356	03280/C	Handgrip with microswitch	12	1394	51901	Spacer spring
1b	3.160.067	01000.60	O-Ring	13	1405	60363	Double pointed spacer
2	1349	03370	Machine torch head	14		51970	Shield cap hand 51102.09 & 51095/L
2a	3.055.623	03310	Machine handle	15		51971	Spacer, contact cutting, 51102/S & 51096/L
3	3.065.204	01070.42	Diffusor	16		51097.10	Extended tip, 50A, shielded
4	1402	52551	Electrode			51097.11	Extended tip, 60A, shielded
5		60001	Swirl ring			51097.12	Extended tip, 70A, shielded
6	1309	51100.09	Tip \varnothing 0.9 35A	17		60321C	Shield cap body CW
	1396	51095	Tip Long Life \varnothing 1.0 50A	18		60503L	Extended shield cap 50-70A
		51100/S	Tip Long Life \varnothing 1.1 60A	19	3.045.012	60368	Wrench for electrode
		51096	Tip Long Life \varnothing 1.2 70A	20	1344	03240/S	Cable, 6m, 1/8", Hand torch
	1308	51100.12	Tip \varnothing 1.2 70A			03250/S	Cable, 12m, 1/8", Hand torch
7		51099	Flat tip \varnothing 1.0	21		03320/S	Cable, 6m, 1/8", Machine torch
		51099.12	Flat tip \varnothing 1.2			03330/S	Cable, 12m, 1/8", Machine torch
8	1305	51098	Conical tip \varnothing 1.0 Low Amp.				

LT-70®

Suitable for
CEBORA® P70®

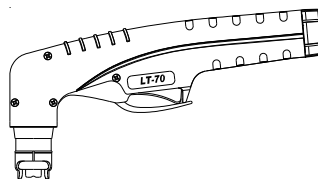

Consumables:
see CEBORA® P70®

Ref.	Code	Description	Ref.	Code	Description
1564	03070LTS	Hand torch, 6m, 1/8" connection		01071	Torch head
1573	03071LTS	Hand torch, 6m, central connector		01000.60	O-Ring
	03170LTS	Hand torch, 12m, 1/8" connection		09606	Handgrip with switch
1573.20	03171LTS	Hand torch, 12m, central connector		07301.20	Switch
	01071/Kit	Torch head with handle			

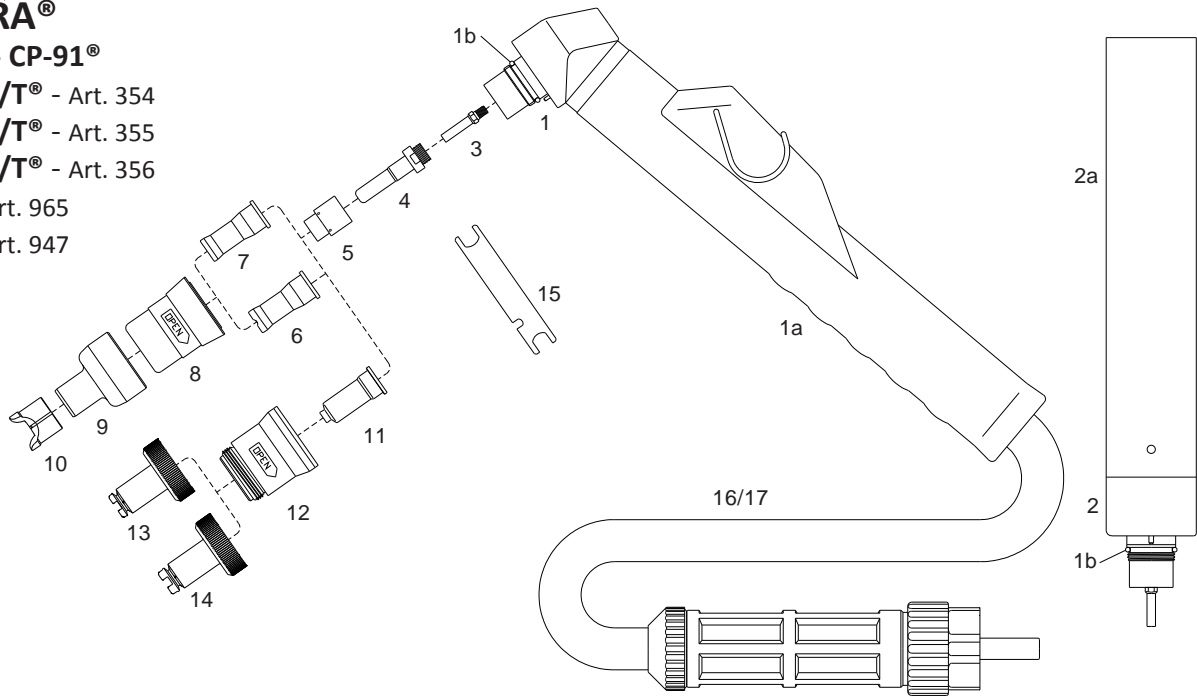
CEBORA®**CP-90® - CP-91®****PC 5060/T® - Art. 354****PC 6060/T® - Art. 355****PC 9060/T® - Art. 356****P55® - Art. 965****P80® - Art. 947**

No.	Ref.	Code	Description	No.	Ref.	Code	Description
	1214	03091/CS	Hand torch, 6m, central connector	10		51973	Spacer for contact cutting hand
	1214.20	03191/CS	Hand torch, 12m, central connector	11		51097.10	Extended tip, 50A, shielded
	1218	03491/S	Machine torch, 6m, central connector			51097.11	Extended tip, 60A, shielded
	1218.20	03591/S	Machine torch, 12m, central connector			51097.12	Extended tip, 70A, shielded
	1215	03090/CS	Hand torch, 6m, 1/8" connection			51097.13	Extended tip, 90-100A, shielded
1	1358	01090	Hand torch head	12		60322C	Shield cap body CCW
1a		04280/C	Handgrip with microswitch	13		60503L	Extended shield cap 50-70A
1b	3.160.067	01000.60	O-Ring	14		60504L	Extended shield cap 80-100A
2	1348	03390	Machine torch head	15	3.045.012	60368	Wrench for electrode
2a	3.055.623	03310	Machine handle	16		03093/S	Cable 6m, 1/8", hand,
3		01090.42	Diffusor				ready for central connector
4	1368	52553	Electrode			03193/S	Cable 12m, 1/8", hand,
5		60001	Swirl Ring				ready for central connector
6		51090	Tip Long Life \varnothing 1.0 - 20-50A item 8 only	17		03493/S	Cable 6m, 1/8", machine,
7		51092	Tip Long Life \varnothing 1.2 - 50-70A item 8 only				ready for central connector
		51093	Tip Long Life \varnothing 1.3 - 70-90A item 8 only			03593/S	Cable 12m, 1/8", machine,
8		60322	Retaining cap for item 6/7 only				ready for central connector
9		51972	Shield cap hand			03240/S	Cable 6m, 1/8", hand

LT-90®

Suitable for
CEBORA® CP-90® CP-91®

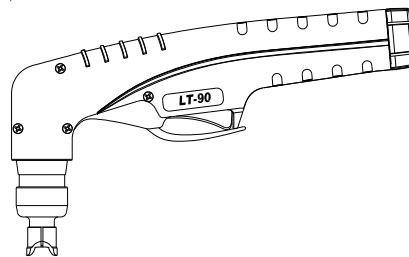

Consumables:
 see **CEBORA® CP-90® CP-91®**

Ref.	Code	Description	Ref.	Code	Description
1215	03090LTS	Hand torch, 6m, 1/8" connection		01091	Torch head
1214	03091LTS	Hand torch, 6m, central connector		01000.60	O-Ring
1214.20	03191LTS	Hand torch, 12m, central connector		09606	Handgrip with switch
	01091/Kit	Torch head with handle		07301.20	Switch

CEBORA®

P150® - CP-160®
P90® Art. 942

P92® Art. 943

P120® Art. 945

P122® Art. 946

P150® Art. 950

P152® Art. 951

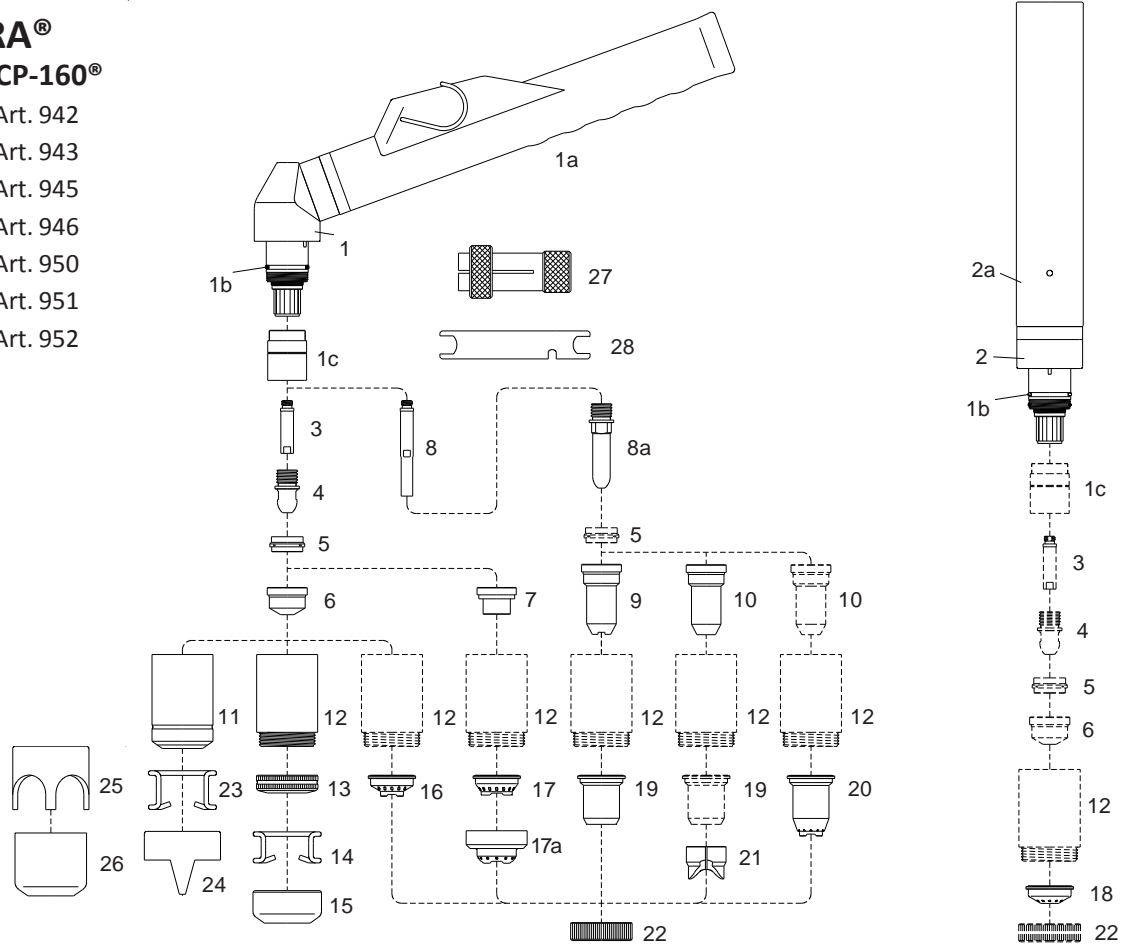
P162® Art. 952

No.	Ref.	Code	Description	No.	Ref.	Code	Description
1226		04053/CS	Hand torch, 6m, central connector	9	1369	51148	Contact extended tip max 50A
1226.20		04153/CS	Hand torch, 12m, central connector	10		51148.13	Extended tip ϕ 1.35 - 90A
1228		08679	Machine torch, 6m shielded, central conn.			51148.16	Extended tip ϕ 1.6 - 120A
1228.20		08685	Machine torch, 12m shielded, central conn.			51148.18	Extended tip ϕ 1.8 - 150A
1571		04050/CS	Hand torch, 6m, 1/8" connection	11	1389	60330	Retaining cap
1576		04051/CS	Hand torch, 6m, central connector	12		60350	Contact retaining cap
1578		04151/CS	Hand torch, 12m, central connector			60350/V	Contact retaining cap, Max Life
1529		04400/S	Machine torch 6m, 1/8" connection	13		51952	Spring holder protection nut
1577		04401/S	Machine torch 6m, central connector	14		51911	Spacer spring for code 51952
1579		04501/S	Machine torch 12m, central connector	15		51953	Gouguing spacer
1	1353	02000	Hand torch head	16		51950	Spacer for contact cutting hand
1a		04280/C	Handgrip with microswitch	17		51930	Spacer for contact cutting hand
1b	1398	02000.60	O-Ring	17a		51920	Spacer for contact cutting hand
1c		60080	Front insulator	18		51951	Shield cup machine
2	1354	04300	Machine torch head	19		51957	Shield cup hand max 50A
2a	3.055.623	03310	Machine handle	20		51958	Spacer for contact cutting hand
3	1378	05004	Diffusor	21		51974	Spacer for extended tips High Amp.
4	1376	52540	Electrode	22		51959	Locking nut
5	1377	60020	Swirl ring	23	1386	51910	Spacer spring
6	1371	51140/S	Tip Long Life ϕ 1.1	24	1408	60370	Double pointed spacer
	1372	51141/S	Tip Long Life ϕ 1.35	25		60371	Crown spacer
	1373	51142/S	Tip Long Life ϕ 1.6	26	1406	60373	Gouguing spacer
	1374	51143/S	Tip Long Life ϕ 1.8	27	1509	60369	Extractor for swirl ring
	1375	51144	Gouguing tip ϕ 3.0	28	3.045.010	60368	Wrench for electrode
7		51410	Contact tip ϕ 1.35			04240/S	Cable, 6m, 1/8", Hand torch
		51411	Contact tip ϕ 1.6			04250/S	Cable, 12m, 1/8", Hand torch
		51412	Contact tip ϕ 1.8			04320/S	Cable, 6m, 1/8", Machine torch
8		05005	Extended diffusor			04330/S	Cable, 12m, 1/8", Machine torch
8a	1517	52549	Extended electrode				

LT-150®

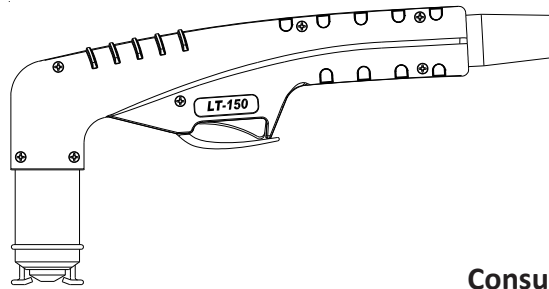

Suitable for
CEBORA® P150® CP-160®

Consumables:
see CEBORA® P-150® CP-160®

Ref.	Code	Description	Ref.	Code	Description
1571	04050LTS	Hand torch, 6m, 1/8" connection	02001		Torch head
1576	04051LTS	Hand torch, 6m, central connector	02000.60		O-Ring
	04150LTS	Hand torch, 12m, 1/8" connection	09706		Handgrip with switch
1578	04151LTS	Hand torch, 12m, central connector	07301.20		Switch
	02001/Kit	Torch head with handle			

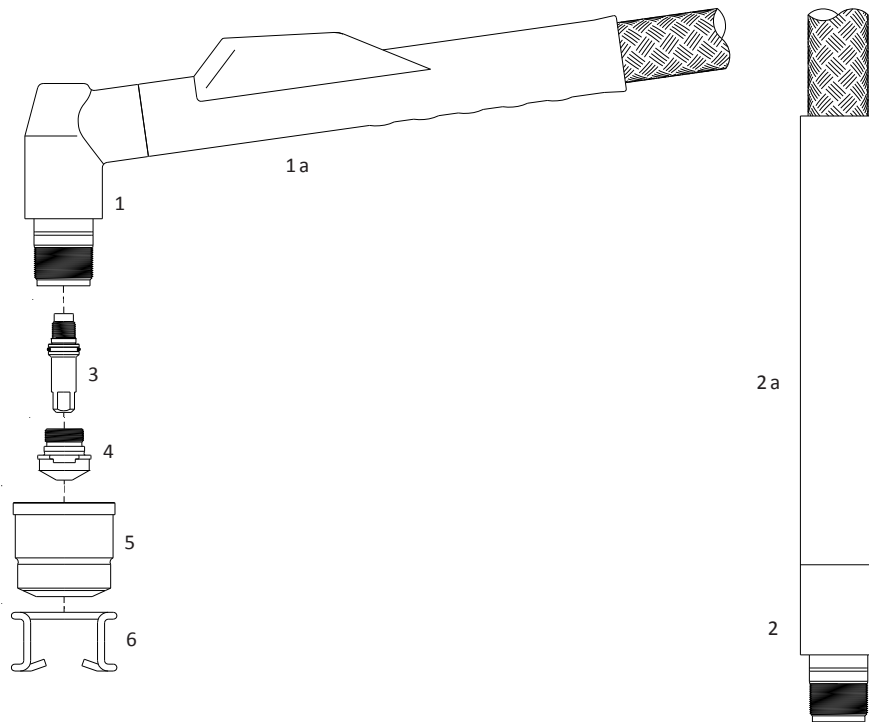
CEBORA®
CP200®

No.	Ref.	Code	Description	Pkg.	No.	Ref.	Code	Description	Pkg.
1	1355	01800	Hand torch head	1	1232	01821/S	Hand torch, 6m textile,		
1a		04280/C	Handgrip with microswitch	1			central connection , 7 pins	1	
2	1357	01810	Machine torch head	1	1232.10	01826/S	Hand torch, 9m textile,		
2a		01815	Machine handle	1			central connection , 7 pin	1	
3	1367	52542	Electrode 200A	5	1235	01831/SH	Machine torch, 4m shielded,		
4	1842	51071	Tip ø 1.0 20-50A	5			central connection , 7 pins	1	
	1843	51072	Tip ø 1.3 40-90A	5	1234	01832/SH	Machine torch, 6m shielded,		
	1844	51073	Tip ø 1.6 80-120A	5			central connection , 7 pins	1	
	1845	51074	Tip ø 1.8 110-150A	5	1234.10	01836/SH	Machine torch, 9m shielded,		
5	1905	60327	Nozzle holder	1			central connection , 7 pins	1	
6	1386	51910	Spacer spring	10					

EWS® LINCOLN®

EX 40 - 2V - EX 60

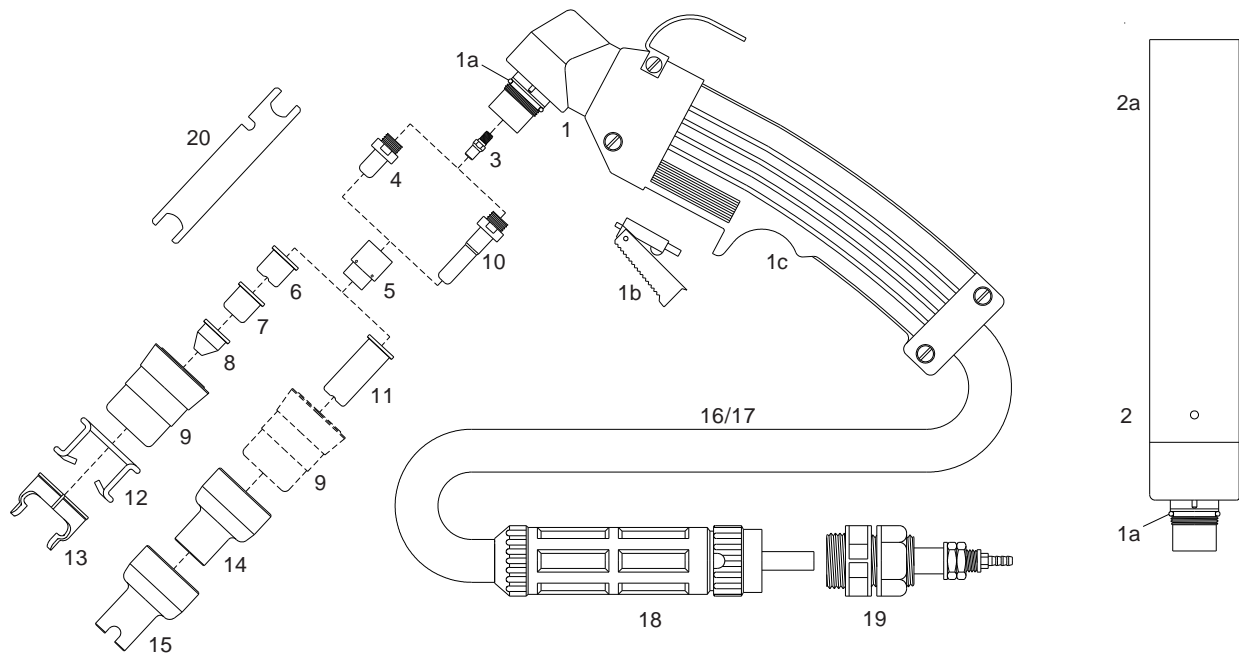

No.	Ref.	Code	Description	No.	Ref.	Code	Description
	W0400030	03072	Hand torch, 6m, central connector	8	W0300151	51098	Pipe saddle tip \varnothing 1.0
		03172	Hand torch, 12m, central connector		W0300152	51098.12	Pipe saddle tip \varnothing 1.2
	W0400046	03472	Machine torch, 6m, central connector	9	W0300109	60321	Retaining cap
	W0400033	03572	Machine torch, 12m, central connector	10	W0300110	52553	Extended electrode
1	W0300100	03270	Hand torch head	11	W0300236	51102.09	Extended tip \varnothing 0.9 35A
1a	W0300101	01000.60	O-Ring		W0300111	51095/L	Extended tip Long Life \varnothing 1.0 50A
1b	W0300103	07301.20	Switch		W0300237	51102/S	Extended tip Long Life \varnothing 1.1 60A
1c	W0300102	07301	Handgrip with switch		W0300112	51096/L	Extended tip Long Life \varnothing 1.2 70A
2	W0300148	03370	Machine torch head	12	W0300113	51901	Spacer spring
2a	W0300144	03310	Machine handle	13	W0300114	60363	Double pointed spacer
3	W0300104	01070.42	Diffusor	14	W0300238	51970	Shield cap hand for 51102.09 & 51095/L
4	W0300105	52551	Electrode	15	W0300239	51971	Spacer contact cutting for 51102/S & 51096/L
5	W0300106	60001	Swirl ring	16	W0300242	03241	Cable, 6m, 1/8", Hand torch
6	W0300155	51100.09	Tip \varnothing 0.9 35A		W0300243	03251	Cable, 12m, 1/8", Hand torch
	W0300107	51095	Tip Long Life \varnothing 1.0 50A	17		03321	Cable, 6m, 1/8", Machine torch
	W0300192	51100/S	Tip Long Life \varnothing 1.1 60A			03331	Cable, 12m, 1/8", Machine torch
	W0300108	51096	Tip Long Life \varnothing 1.2 70A	18	W0300117	04260-EWS	Central connector torch side
	W0300193	51100.12	Tip \varnothing 1.2 70A	19	W0300118	04265-EWS	Central connector machine side
7	W0300149	51099	Flat tip \varnothing 0.9	20	W0300119	60368	Wrench for electrode
	W0300150	51099.12	Flat tip \varnothing 1.2				

Notes

EWS® LINCOLN®

EX 100

EX 100 M

EX 100 M-3V

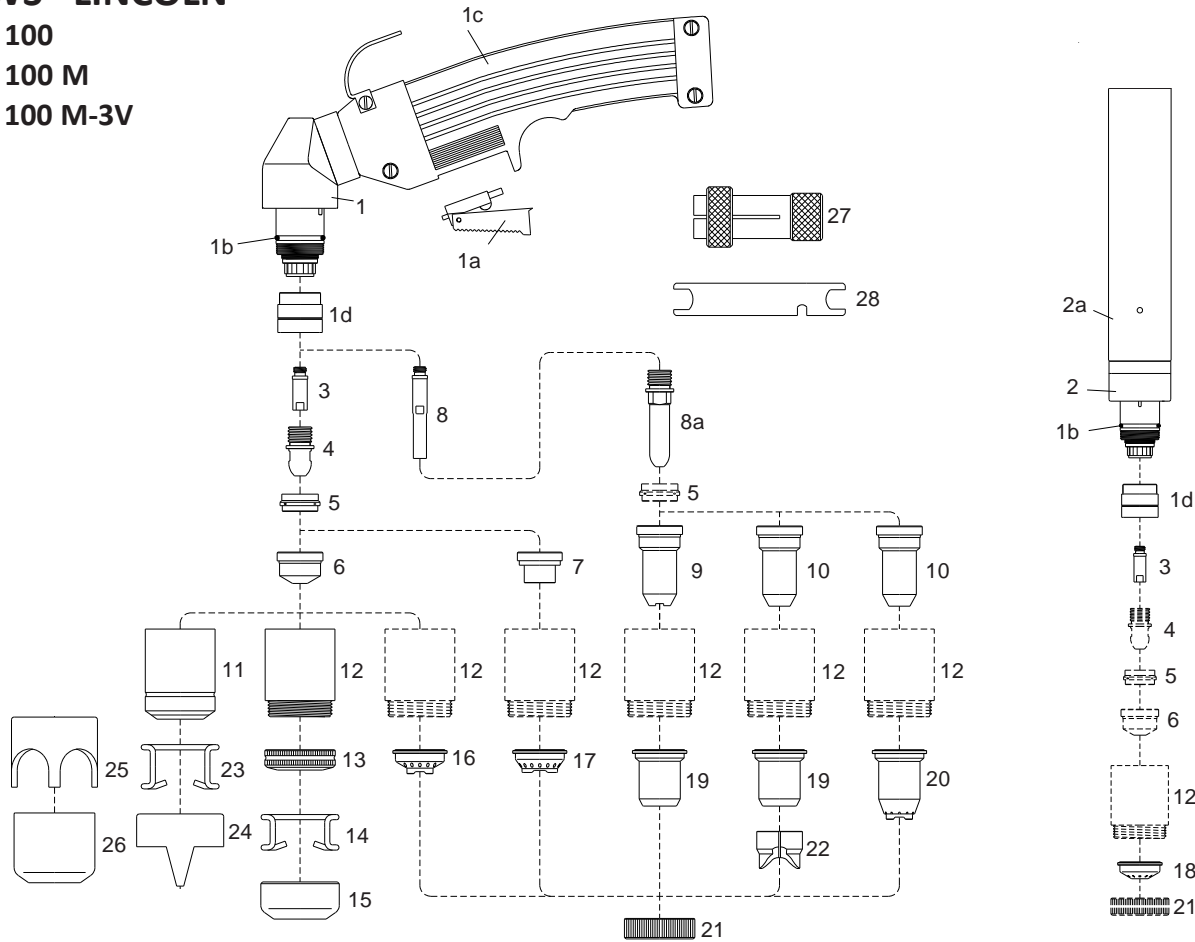

No.	Ref.	Code	Description	No.	Ref.	Code	Description			
		W0400052	01252	Hand torch 6m central connection						
		W0400037	01352	Hand torch 12m central connection						
		W0400034	01452	Machine torch 6m central connection						
		W0400035	01552	Machine torch 12m central connection						
1	W0300263	01200	Hand torch head	11	W0300129	60328	Retaining cap			
1a	W0300103	07301.20	Switch	12	W0300138	60348	Contact retaining cap			
1b	W0300121	02000.60	O - Ring			60348/V	Contact retaining cap, Max.life			
1c	W0300102	07301	Handgrip complete with switch	13	W0300244	51952	Spring holder protection nut			
1d		60085	Front insulator	14	W0300245	51911	Spacer spring for code 51952			
2	W0300143	01400	Machine torch head	15		51953	Gouging spacer			
2a	W0300144	03310	Machine handle	16	W0300180	51950	Spacer for contact cutting, hand			
3	W0300122	06004	Diffusor	17		51930	Spacer for contact cutting, hand			
4	W0300123	52540	Electrode	18	W0300181	51951	Shield cup, machine			
5	W0300124	60020	Swirl ring	19	W0300182	51957	Shield cup, hand (max. 50A)			
6		51140/S	Tip long life \varnothing 1.1	20	W0300183	51958	Spacer for contact cutting, hand			
		W0300174	51141/S	Tip long life \varnothing 1.35	21	W0300184	51959	Locking nut		
		W0300175	51142/S	Tip long life \varnothing 1.6	22		51974	Spacer for extended tips High Amp.		
		W0300128	51144.24	Gouging tip \varnothing 2.4	23	W0300130	51910	Spacer spring		
7	W0300135	51410	Contact tip \varnothing 1.35	24	W0300131	60370	Double pointed spacer			
		W0300137	51411	Contact tip \varnothing 1.6	25	W0300177	60371	Crown spacer		
8		06005	Extended diffusor	26	W0300132	60373	Gouging spacer			
8a	W0300133	52549	Extended electrode			W0300140	04241	Cable, 6m 1/8" - Hand torch		
9	W0300134	51148	Extended tip (for contact cutting max. 50A)			W0300141	04251	Cable, 12m 1/8" - Hand torch		
10	W0300178	51148.13	Extended tip \varnothing 1.35 - 90A (51958 + 51959)			W0300189	04321	Cable, 6m 1/8" - Machine torch		
		W0300179	51148.16	Extended tip \varnothing 1.6 - 120A (51958 + 51959)			04331	Cable, 12m 1/8" - Machine torch		
							W0300117	04260-EWS	Central connector torch side	
							W0300118	04265-EWS	Central connector machine side	
							27	W0300142	60369	Extractor for swirl ring
							28	W0300119	60368	Wrench for electrode

EWS® LINCOLN® EX 100 RF

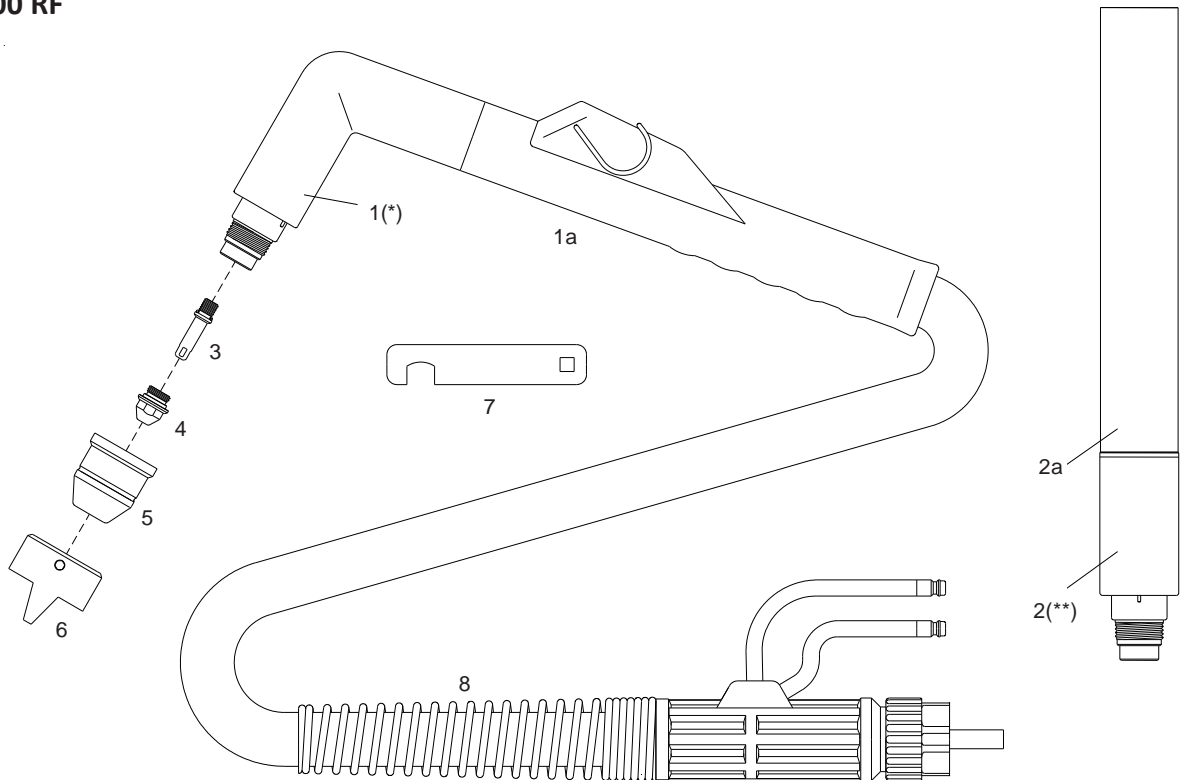

(*) with parts in place and 60354
(**) with parts in place and 80054

No.	Ref.	Code	Description	Pkg.	No.	Ref.	Code	Description	Pkg.
	W0400038	07822	Hand torch 6m central connector	1	4	W0300165	51271/CU	Tip \varnothing 1.3 80A	10
	W0400039	07832	Hand torch 12m central connector	1		W0300161	51272/CU	Tip \varnothing 1.6 120A	10
	W0400040	07842	Machine torch 6m central connector	1		W0300166	51273/CU	Tip \varnothing 1.8 150A	10
	W0400041	07852	Machine torch 12m central connector	1	5	W0300167	80054	Shield cap	10
1	W0300171	07800	Hand torch head (*)	1			60354	Fiberglass shield cap	10
1a	W0300172	04280/C	Handgrip with microswitch	1	6	W0300265	60374	Double pointed spacer	6
2	W0300169	07810	Machine torch head (**)	1	7	W0300250	07800.57	Wrench for tip and electrode	1
2a	W0300168	07215	Machine handle	1	8	W0300173	07882	Cable 6m Hand torch central connector	1
3	W0300160	52751	Electrode with O-Ring	10		W0300247	07887	Cable 12m Hand torch central connector	1
4	W0300163	51269/CU	Tip \varnothing 0.8 30A	10			07892	Cable 6m Machine torch central connector	1
	W0300164	51270/CU	Tip \varnothing 1.0 50A	10			07897	Cable 12m Machine torch central connector	1

Notes

TELWIN®

PLASMA 34 KOMPRESSOR®
PLASMA 54 KOMPRESSOR®
PLASMA 41®

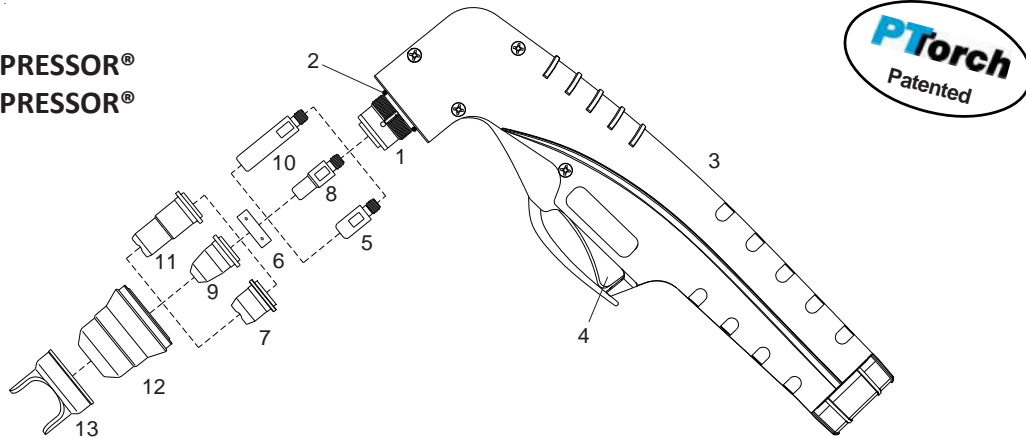

No.	Ref.	Code	Description	No.	Ref.	Code	Description
	742239	09620/TW20	Hand torch PT-20C, 4m	9	802092	51316.06	Tip \varnothing 0.65
	742237	09620/TW25	Hand torch PT-25, 4m			51316	Tip \varnothing 0.8
	742065	09620/TW30	Hand torch PT-40, 4m		802423	51316.09	Tip \varnothing 0.9
1	742474	09600	Torch head	10	802428	52532	Extended electrode
2		51620.60	O-Ring	11		51317.06	Extended tip \varnothing 0.65
3	742475	09605/R	Handle with Switch		802429	51317.09	Extended tip \varnothing 0.9
4		07301.20	Switch			51317	Extended tip \varnothing 1.0
5	802421	52536	Electrode	12	802425	60389	Retaining cap
6	802422	60028	Swirl ring		802096	60389S-1	Retaining cap (1 hole)
7		51315.09	Tip \varnothing 0.9			60389K	Retaining cap (2 holes)
	802424	51315	Tip \varnothing 1.0		802485	60389K4	Retaining cap (4 holes)
8	802420	52531	Electrode	13		60431	Double Pointed Spacer

TELWIN®

SUPERIOR PLASMA 60 HF®
SUPER PLASMA 80/3 HF®

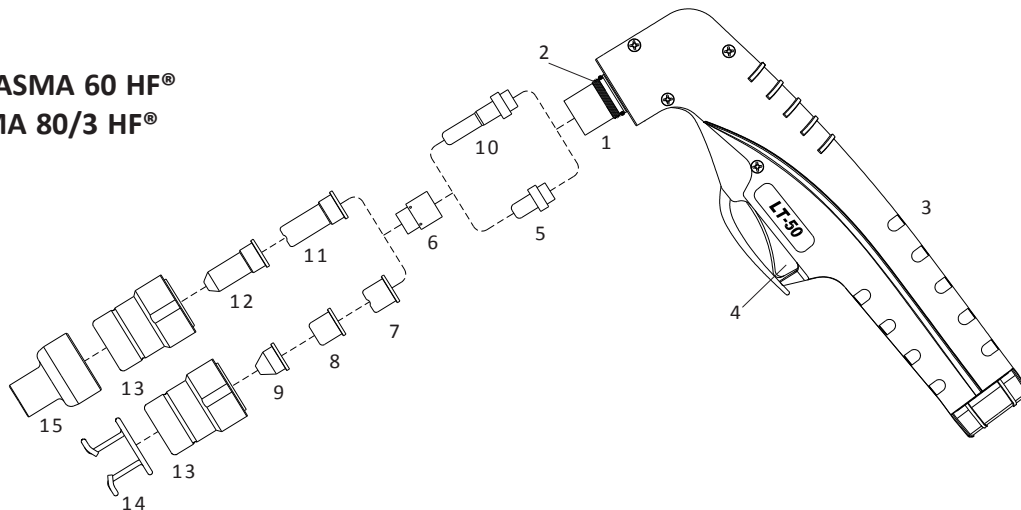

No.	Ref.	Code	Description	No.	Ref.	Code	Description
	742040	03051LTR-TW	Hand torch, 6m, central connector	8		51099	Flat tip \varnothing 1.0
	722474	03050LTR-TW	Hand torch, 6m, 9/16" connection	9		51098	Conical tip \varnothing 1.0 Low Amp.
1		01001	Hand torch head	10	802078	52513/L	Extended electrode
2		01000.60	O-Ring	11	802079	51102	Extended tip \varnothing 1.0
3	742478	09606/R	Handgrip with switch			51095/L	Extended tip Long Life \varnothing 1.0
4		07301.20	Switch			51102/S	Extended tip Long Life \varnothing 1.1
5	802076	52512/L	Electrode	12		51101	Extended conical tip \varnothing 1.0
6	802080	60001	Swirl ring	13	802081	60320/I	Retaining cap
7	802077	51100	Tip \varnothing 1.0	14	802128	51901	Spacer Spring
		51095	Tip Long Life \varnothing 1.0	15		51965	Shield cap, hand, extended tips
		51100/S	Tip Long Life \varnothing 1.1				

TELWIN®

ENTERPRISE PLASMA 160 HF®

SUPER PLASMA 120/3 HF®

SUPERIORPLASMA 90 HF®

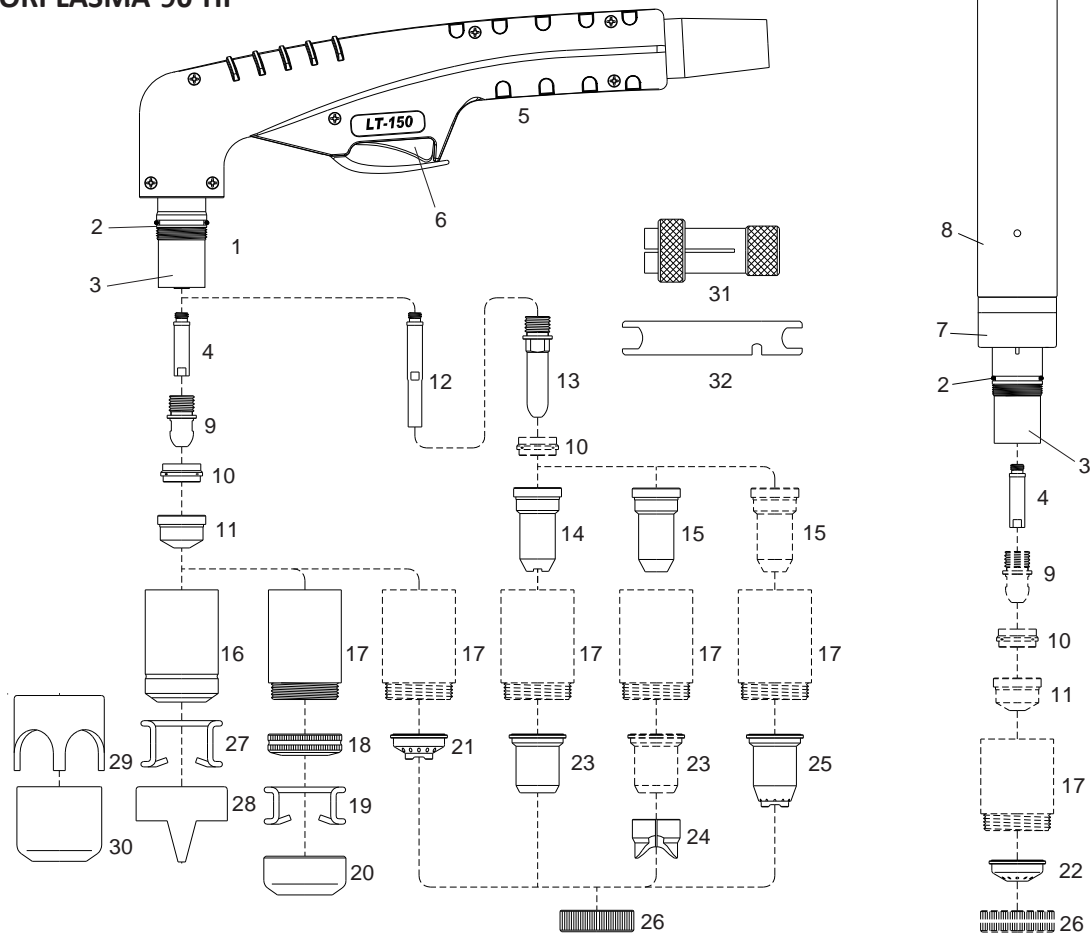

No.	Ref.	Code	Description	No.	Ref.	Code	Description
	722332	04051LTR-TW	Hand torch, 6m, cent. connector	15		51148.13	Extended tip \varnothing 1.35 - 90A
	722333	04151LTR-TW	Hand torch, 12m, cent. connector			51148.16	Extended tip \varnothing 1.6 - 120A
	722334	04501-TW	Machine torch, 12m, cent. connector			51148.18	Extended tip \varnothing 1.8 - 150A
1		02001	Hand torch head	16	802126	60330	Retaining cap
2	802120	02000.60	O-Ring	17		60350	Contact retaining cap
3		60080	Front insulator			60350/V	Contact retaining cap, Max Life
4		05004	Diffusor	18		51952	Spring holder protection nut
5		09706/R	Handgrip with switch	19		51911	Spacer spring for code 51952
6		07301.20	Switch	20		51953	Gouging spacer
7		04300	Machine torch head	21		51950	Shield cup hand
8		03310	Machine handle	22		51951	Shield cup machine
9		52540	Electrode	23		51957	Shield cup hand max 50A
10	802123	60020	Swirl ring	24		51958	Spacer contact cutting hand
11		51140/S	Tip Long Life \varnothing 1.1	25		51974	Spacer extended tips High Amp.
	802119	51141/S	Tip Long Life \varnothing 1.35	26		51959	Locking nut
	802124	51142/S	Tip Long Life \varnothing 1.6	27	802127	51910	Spacer spring
	802125	51143/S	Tip Long Life \varnothing 1.8				
		51144.24	Gouging tip \varnothing 2.4 120A	28		60370	Double pointed spacer
		51144	Gouging tip \varnothing 3.0 150A	29		60371	Crown spacer
12	802121	05005	Extended diffusor	30		60373	Gouging spacer
13		52549	Extended electrode	31		60369	Extractor for swirl ring
14	802083	51148	Contact extended tip max 50A	32		60368	Wrench for electrode

TRAFIMET® A53 - S54

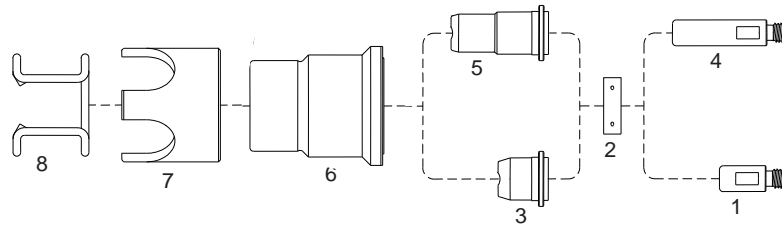

No.	Ref.	Code	Description	No.	Ref.	Code	Description
1	PR105	52536	Electrode	5	PD103-09	51317.09	Extended tip ϕ 0.9
2	PE106	60028	Swirl ring	6	PC115	60384	Retaining cap for S54
3	PD102-10	51315	Tip ϕ 1.0	7	CV33	60378	Crown spacer
4	PR106	52532	Extended electrode	8	CV28	51902	Spacer spring

TRAFIMET® A60

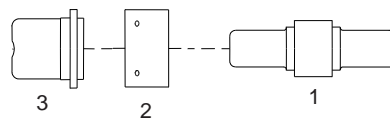

No.	Ref.	Code	Description	No.	Ref.	Code	Description
1	PR107	52537	Electrode	3	PD105.10	51170	Tip ϕ 1.0
2	PE107	60029	Swirl ring		PD105.11	51172	Tip ϕ 1.1

Series PT Suitable for TRAFIMET® S25 - S25 K S30 - S35 K S45

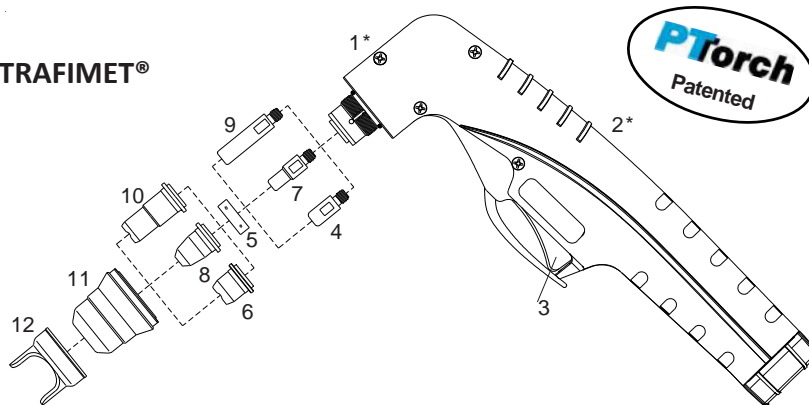

* parts not interchangeable with the OEM

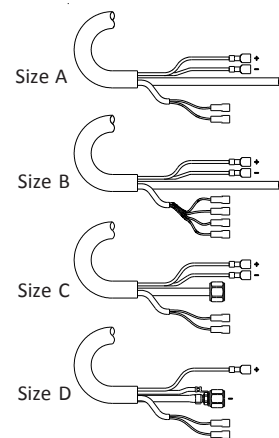

No.	Ref.	Code	Description	No.	Ref.	Code	Description
	PA0370	09622	Hand torch PT-20C, 4m, size B		PD0116-08	51316	Tip ϕ 0.8
	PA0375	09623	Hand torch PT-20C, 4m, size A		PD0116-09	51316.09	Tip ϕ 0.9
	PA0376	09620	Hand torch PT-20C, 4m, size A	9	PR0106	52532	Extended electrode
	PA0167	09632	Hand torch PT-40, 4m, 1/4G, size C	10	PD0103-65	51317.06	Extended tip ϕ 0.65
	PA0165	09634	Hand torch PT-40, 6m, 1/4G, size D		PD0103-09	51317.09	Extended tip ϕ 0.9
	PA0166	09635	Hand torch PT-40, 6m, central conn.		PD0103-10	51317	Extended tip ϕ 1.0
1*		09600	Torch head PT-20C	11	PC116	60389	Retaining cap
		09602	Torch head PT-40		PC122	60389K1	Retaining cap (1 hole)
2*		09605	Handle with Switch		PC117	60389K	Retaining cap (2 holes)
3	BX0020	07301.20	Switch			60389K4	Retaining cap (4 holes)
4	PR0105	52536	Electrode	12		60431	Double Pointed Spacer
5	PE0106	60028	Swirl ring	*		09682	Cable 4m, PT-20C, size B
6	PD0102-09	51315.09	Tip ϕ 0.9	*		09680	Cable 4m, PT-20C, size A
	PD0102-10	51315	Tip ϕ 1.0	*		09687	Cable 4m, PT-40, 1/4G, size C
7	PR0110	52531	Electrode	*		09688	Cable 6m, PT-40, 1/4G, size D
8	PD0116-06	51316.06	Tip ϕ 0.65	*		09689	Cable 6m, PT-40, cent. conn.

TRAFIMET® A80-P80®

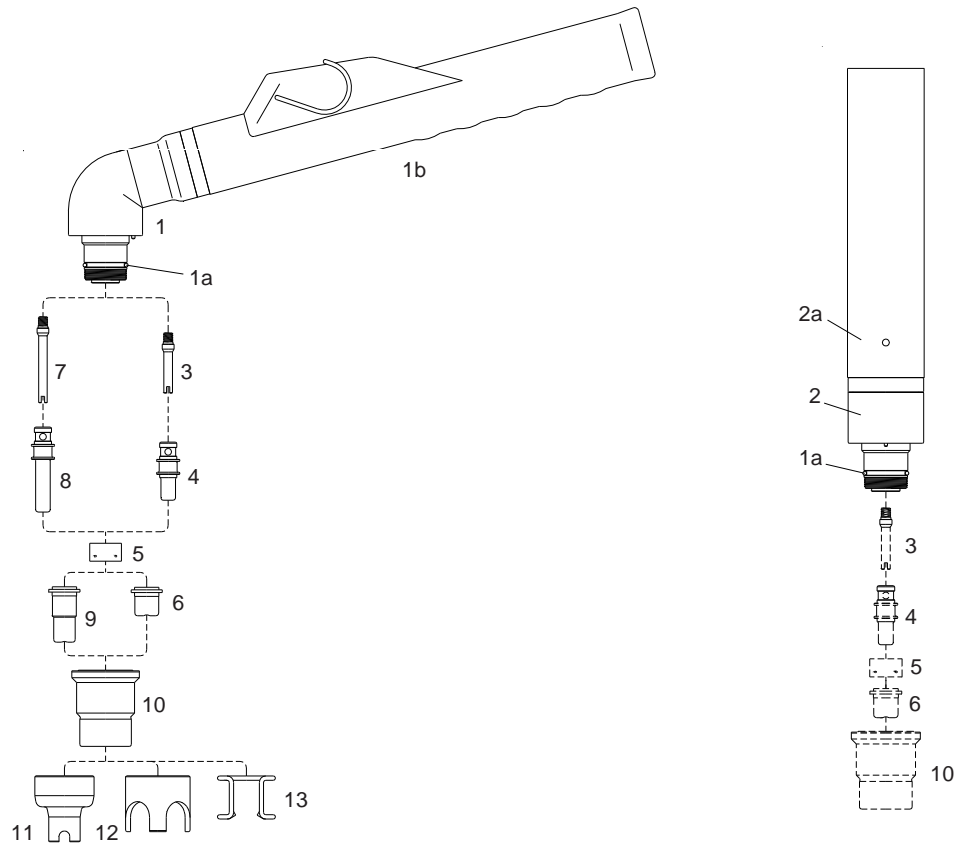

No.	Ref.	Code	Description	No.	Ref.	Code	Description
	PA170	06820	Hand torch 6m 3/8 G - 1/4 G	6	PD105-11	51172	Tip \varnothing 1.1
	PA1402	06821	Hand torch 6m cent. connector		PD105-12	51172.12	Tip \varnothing 1.2
	PA180	06840	Machine torch 6m 3/8 G	7	FH0561	06801.43	Extended diffuser
	PA181	06841	Machine torch 6m cent. connector	8	PR115	52581/S	Extended electrode
1	PF119	06800	Hand torch head	9	PD106-10	51171.10	Extended tip \varnothing 1.0
1a	EA125	07300.60	O-Ring		PD106-12	51173	Extended tip \varnothing 1.2
1b		04280/c	Handgrip with microswitch	10	PC115	60384	Retaining cap
2	PF120	06811	Machine torch head	11	CV201	51976	Spacer for contact cutting
2a	TP61	06815	Machine handle	12	CV33	60378	Crown spacer
3	FH0560	06801.42	Diffuser	13	CV28	51902	Spacer spring
4	PR109	52580/S	Electrode		PH130/132	06880	Cable 6m 3/8G - 1/4G
5	PE107	60029	Swirl ring		PF107	06800/KIT	Kit for replacing "A60"
6	PD105-10	51170	Tip \varnothing 1.0				

LT-81®

Suitable for **ERGOCUT® A81®**
TRAFIMET® A80®

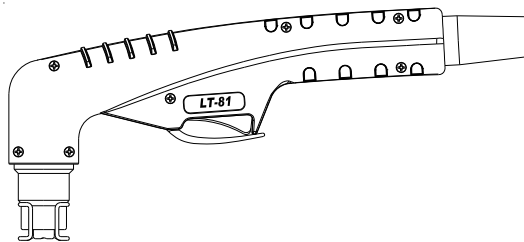

Consumables:
see **A80-A81®**

Ref.	Code	Description	Ref.	Code	Description
PA170/1400/1404	06820LT	Hand torch, 6m, 3/8G connection	EA0125	07300.60	O-Ring
PA1402	06821LT	Hand torch, 6m, central connector		09706	Handgrip with switch
PF0140	06802/KIT	Torch head with handle	BX0020	07301.20	Switch
	06802	Torch head			

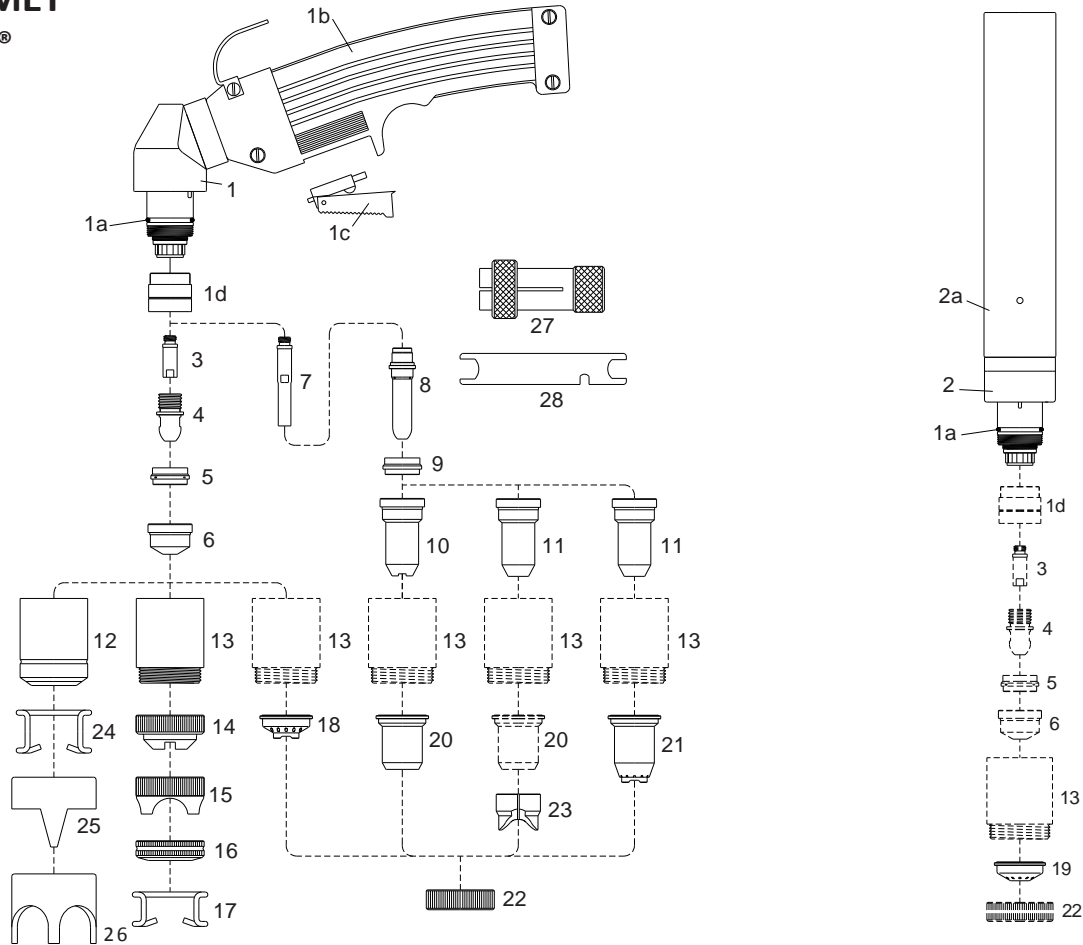
TRAFIMET®
A90-P90®

No.	Ref.	Code	Description	No.	Ref.	Code	Description
	PA109	06050	Hand torch 6m M14x1	11	PD117-14	51149.14	Extended tip \varnothing 1.4
		06051	Hand torch 6m central connector		PD117-17	51149.17	Extended tip \varnothing 1.7
	PA209	06150	Hand torch 12m M14x1	12	PC109/111	60376	Retaining cap, long life
		06151	Hand torch 12m (central connector)	13	PC113/130	60386	Contact retaining cap
	PA110	06650	Machine torch 6m M14x1		PC113/130	60386/v	Contact retaining cap, Max.life
	PA111	06651	Machine torch 6m central connector	14	CV23	51940	Spacer for contact cutting
		06750	Machine torch 12m M14x1	15	CV39	51945	Large spacer for contact cutting
		06751	Machine torch 12m central connector	16		51952	Spring holder protection nut
1	PF109	06000	Hand torch head	17		51911	Spacer spring for code 51952
1a	EA131	06000.60	O-Ring	18		51950	Spacer for contact cutting, hand
1b		07301	Handgrip complete with switch	19		51951	Shield cup, machine
1c		07301.20	Switch	20	CV8	51957	Shield cup, hand max. 50A
1d		60085	Front insulator	21	CV9	51958	Spacer for contact cutting, hand
2	PF115	06600	Machine torch head	22		51959	Locking nut
2a		03310	Machine handle	23		51974	Spacer for extended tips High Amp.
3		06004	Diffusor	24	CV11	51910	Spacer spring
4	PR101	52535	Electrode	25	CV12	60370	Double pointed spacer
5	PE101	60030	Swirl ring	26	CV14	60371	Crown spacer
6	PD101-11	51154	Tip \varnothing 1.1	27	GR60	60369	Extractor for swirl ring
	PD101-14	51155	Tip \varnothing 1.4	28		60368	Wrench for electrode
	PD101-17	51156	Tip \varnothing 1.7			04224	Cable 6m M14x1 - Hand torch
7		06005	Extended Diffusor			04234	Cable 12m M14x1 - Hand torch
8	PR116	52530	Extended electrode			04222	Cable 6m M14x1 - Machine torch
9	PE103	60031	Insulating spacer			04232	Cable 12m M14x1 - Machine torch
10	PD111	51149	Extended tip \varnothing 1.1 (max. 50A)				

TRAFIMET® A140-P140®

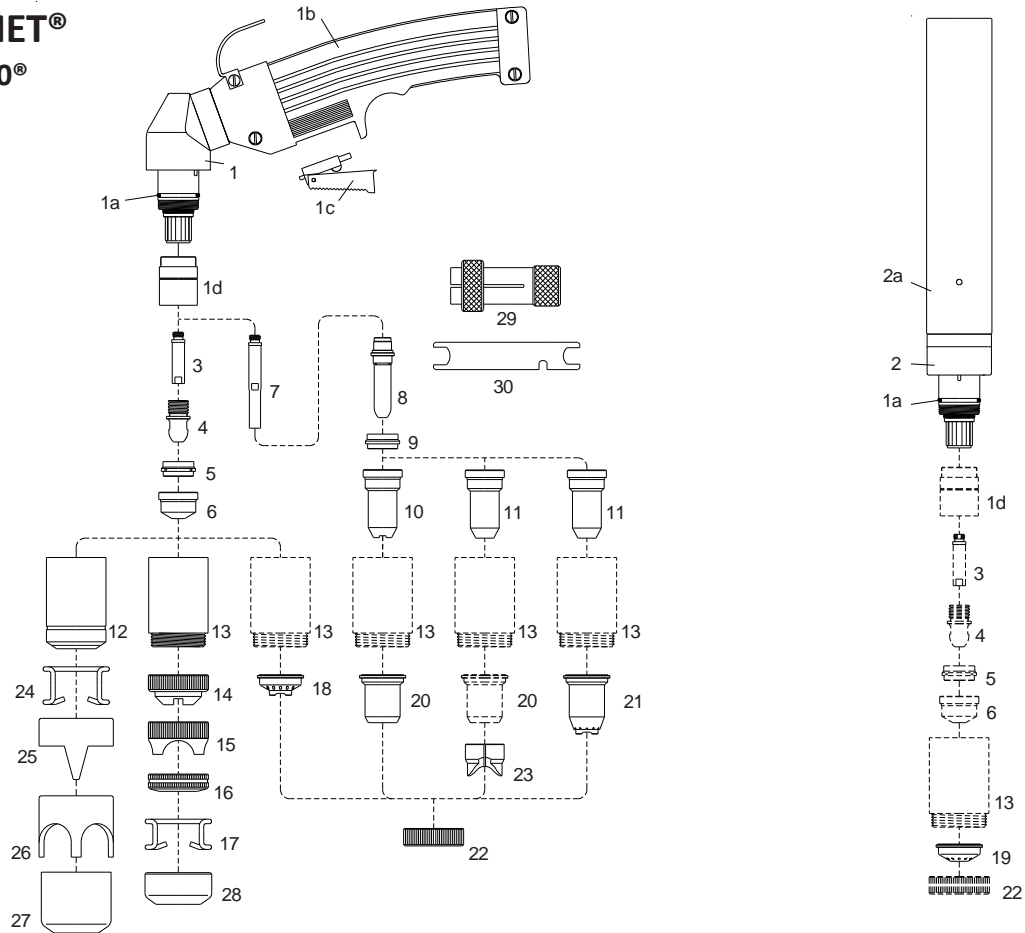

No.	Ref.	Code	Description	No.	Ref.	Code	Description
PA101	06250		Hand torch 6m M14 x 1	11	PD117-14	51149.14	Extended tip ø 1.4
	06251		Hand torch 6m cent. connector			51149.17	Extended tip ø 1.7
PA102	06350		Hand torch 12m M14 x 1			51149.19	Extended tip ø 1.9
	06351		Hand torch 12m cent. connector	12	PC101/102	60375	Retaining cap, long life
PA103	06450		Machine torch 6m M14 x 1	13	PC103/131	60385	Contact retaining cap
PA145	06451		Machine torch 6m cent. connector		PC103/131	60385/V	Contact retaining cap, Max.life
PA104	06550		Machine torch 12m M14 x 1	14	CV23	51940	Spacer for contact cutting
PA146	06551		Machine torch 12m cent.conn.	15	CV39	51945	Large spacer for contact cutting
1	PF101	06200	Hand torch head	16		51952	Spring holder protection nut
1a	EA131	06000.60	O - Ring	17		51911	Spacer spring for code 51952
1b		07301	Handgrip complete with switch	18		51950	Spacer for contact cutting, hand
1c		07301.20	Switch	19		51951	Shield cup, machine
1d		60080	Front insulator	20	CV8	51957	Shield cup, hand (max. 50A)
2	PF102	06400	Machine torch head	21	CV9	51958	Spacer for contact cutting, hand
2a		03310	Machine handle	22		51959	Locking nut
3		05004	Diffusor	23		51974	Spacer for extended tips High Amp.
4	PR101	52535	Electrode	24	CV11	51910	Spacer spring
5	PE101	60030	Swirl ring	25	CV12	60370	Double pointed spacer
6	PD101 - 11	51154	Tip ø 1.1	26	CV14	60371	Crown spacer
	PD101 - 14	51155	Tip ø 1.4	27	CV13	60373	Gouging spacer
	PD101 - 17	51156	Tip ø 1.7	28		51953	Gouging spacer
	PD101 - 19	51157	Tip ø 1.9	29	GR60	60369	Extractor for swirl ring
	PD101 - 30	51158	Gouging tip ø 3.0	30		60368	Wrench for electrode
7		05005	Extended Diffusor			04220	Cable 6m M14 x 1 - Hand torch
8	PR116	52530	Extended electrode			04230	Cable 12m M14 x 1 - Hand torch
9	PE103	60031	Insulating spacer			04222	Cable 6m M14 x 1 - Machine torch
10	PD111	51149	Extended tip ø 1.1 (max. 50A)			04232	Cable 12m M14 x 1 - Machine torch

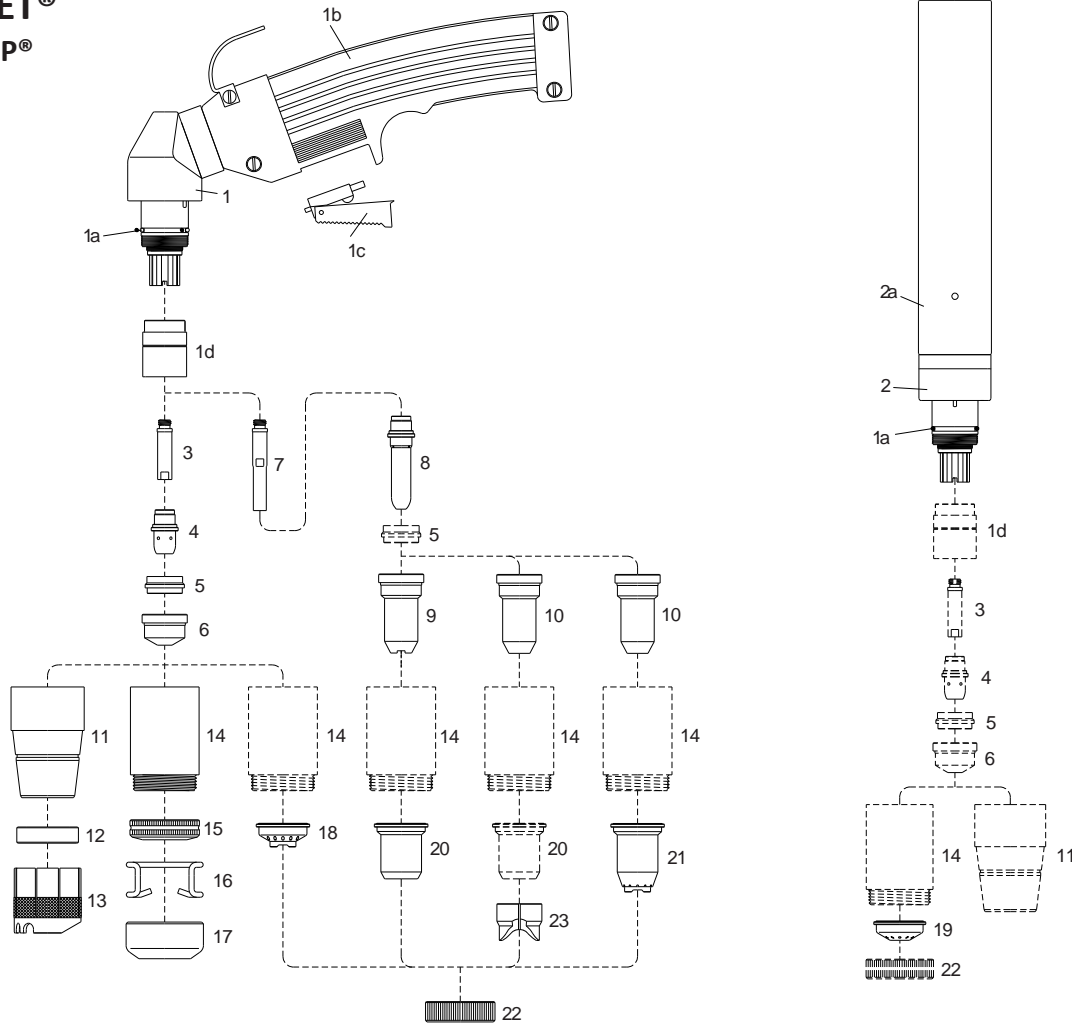
TRAFIMET®
R145-R145P®

No.	Ref.	Code	Description	No.	Ref.	Code	Description
	PA129	06920/S	Hand torch 6m M14 x 1	8	PR116	52530	Extended electrode
		06921/S	Hand torch 6m cent. connector	9	PD111	51149	Extended tip \varnothing 1.1 (max 50A)
	PA130	06930/S	Hand torch 12m M14 x 1	10	PD117-14	51149.14	Extended tip \varnothing 1.4
		06931/S	Hand torch 12m cent. conn.		PD117-17	51149.17	Extended tip \varnothing 1.7
	PA127	06940/S	Machine torch 6m M14 x 1		PD117-19	51149.19	Extended tip \varnothing 1.9
	PA252	06941/S	Machine torch 6m cent. conn.	11	PC120	60387	Retaining cap
	PA128	06950/S	Machine torch 12m M14 x 1	12	BW139	60388	Nozzle shield
	PA253	06951/S	Machine torch 12m cent. conn.	13	CV1105	60379	Cage spacer
1	PF112	06900	Hand torch head	14	PC103/131	60385	Contact retaining cap
1a	EA131	06000.60	O - Ring		PC103/131	60385/V	Contact retaining cap, Max.life
1b		07301	Handgrip complete with switch	15		51952	Spring holder protection nut
1c		07301.20	Switch	16		51911	Spacer spring for code 51952
1d		60080	Front insulator	17		51953	Gouging spacer
2	PF111	06910	Machine torch head	18		51950	Spacer for contact cutting, hand
2a		03310	Machine handle	19		51951	Shield cup, machine
3		05004	Diffusor	20	CV8	51957	Shield cup, hand (max. 50A)
4	PR111	52534	Electrode	21	CV9	51958	Spacer for contact cutting, hand
5	PE103	60031	Insulating spacer	22		51959	Locking nut
6	PD109-14	51241	Tip \varnothing 1.4	23		51974	Spacer for extended tips High Amp.
	PD109-16	51242	Tip \varnothing 1.6			04220/S	Cable 6m (M14x1) - Hand torch
	PD109-18	51243	Tip \varnothing 1.8			04230/S	Cable 12m (M14x1) - Hand torch
	PD109-30	51244	Gouging tip \varnothing 3.0			04222/S	Cable 6m (M14x1) - Machine torch
7		05005	Extended Diffusor			04232/S	Cable 12m (M14x1) - Machine torch

LT-101®

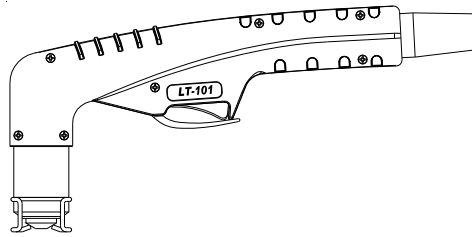

Suitable for **ERGOCUT® A101®**
TRAFIMET® A90®

Consumables:
see **A90-A101®**

Ref.	Code	Description	Ref.	Code	Description
PA109/1450/1454	06050LT	Hand torch, 6m, M14x1		06001	Torch head
PA1452	06051LT	Hand torch, 6m, central connector	EA0131	06000.60	O-Ring
PA209	06150LT	Hand torch, 12m, M14x1		09706	Handgrip with switch
	06151LT	Hand torch, 12m, central connector	BX0020	07301.20	Switch
PF0145	06001/Kit	Torch head with handle			

LT-141®

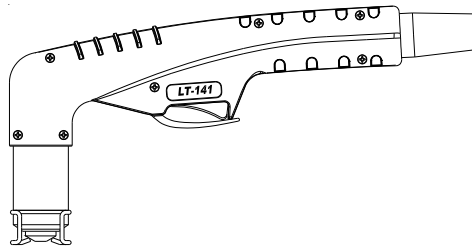

Suitable for **ERGOCUT® A141®**
TRAFIMET® A140®

Consumables:
see **A140-A141®**

Ref.	Code	Description	Ref.	Code	Description
PA101/1500/1502	06250LT	Hand torch, 6m, M14x1		06201	Torch head
PA1504	06251LT	Hand torch, 6m, central connector	EA0131	06000.60	O-Ring
PA102/1501	06350LT	Hand torch, 12m, M14x1		09706	Handgrip with switch
PA1505	06351LT	Hand torch, 12m, central connector	BX0020	07301.20	Switch
PF0155	06201/Kit	Torch head with handle			

LT-151®

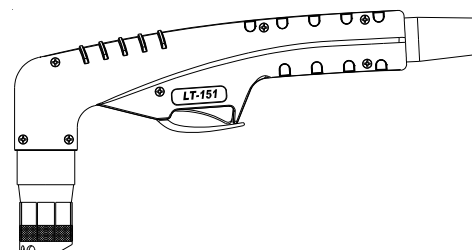

Suitable for **ERGOCUT® A151®**
TRAFIMET® R145®

Consumables:
see **R145-A151®**

Ref.	Code	Description	Ref.	Code	Description
PA129/1550/1552	06920LTS	Hand torch, 6m, M14x1		06901	Torch head
PA1554	06921LTS	Hand torch, 6m, central connector	EA0131	06000.60	O-Ring
PA130/1551	06930LTS	Hand torch, 12m, M14x1		09706	Handgrip with switch
PA1555	06931LTS	Hand torch, 12m, central connector	BX0020	07301.20	Switch
PF0160	06901/Kit	Torch head with handle			

Circle Cutting attachments are supplied in plastic boxes

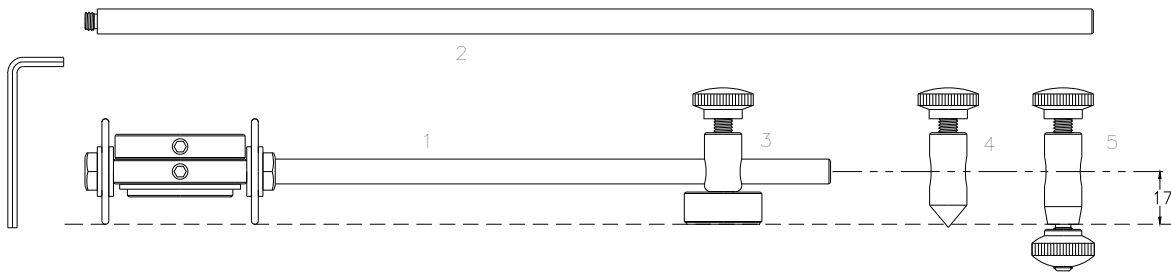

No.	Ref.	Code	Description	No.	Ref.	Code	Description
1		51820	Radius bar mm250			51865	Circle cutting attachment HY [®]
2		51821	Radius bar mm400				Powermax 600/800/900/1000/1650 [®]
3		51826	Magnetic base assembly			51804	Cutting guide HY [®]
4		51827	Free centering straight pin				Powermax 600/800/900/1000/1650 [®]
5		51828	Straight locking pin			51856	Circle cutting attachment BZ [®] PSB60/80/121 [®]
166		51850	Circle cutting attachment CEB [®] P50 [®]			51812	Cutting guide BZ [®] PSB 60/80/121 [®]
154		51806	Cutting guide CEB [®] P50 [®]			51855	Circle cutting attachment BZ [®] PSB 31/31KK [®]
166-70		51849	Circle cutting attachment CEB [®] P70 [®]			51811	Cutting guide BZ [®] PSB 31/31KK [®]
154-70		51801	Cutting guide CEB [®] P70 [®]			51858	Circle cutting attachment SF [®] CP40R/CP100R [®]
		51849	Circle cutting attachment EWS [®] EX 60 [®]			51814	Cutting guide SF [®] CP40R/CP100R [®]
		51801	Cutting guide EWS [®] EX 60 [®]			51861	Circle cutting attachment TRA [®] A53 to A81 [®]
163		51848	Circle cutting attachment CEB [®] CP90 [®]			51817	Cutting guide TRA [®] A53 to A81 [®]
153		51818	Cutting guide CEB [®] CP90 [®]			51866	Circle cutting attachment PT-20C [®] / PT40 [®]
		51860	Circle cutting attachment EWS [®] EX100RF [®]			51823	Cutting guide PT-20C [®] / PT40 [®]
		51816	Cutting guide EWS [®] EX100RF [®]			51864	Circle cutting attachment EUROLOK [®]
		51860	Circle cutting attachment OTC [®] D12000 [®]			51802	Cutting guide EUROLOK [®]
		51816	Cutting guide OTC [®] D12000 [®]			51864	Circle cutting attachment UNITORCH [®]
		51853	Circle cutting attachment HY [®] MAX 40/42 [®]			51802	Cutting guide UNITORCH [®]
		51809	Cutting guide HY [®] MAX 40/42 [®]			51846	Circle cutting attachment TD [®] PCH25 to 80 [®]
						51803	Cutting guide TD [®] PCH25 to PCH80 [®]

Circle Cutting attachments are supplied in plastic boxes

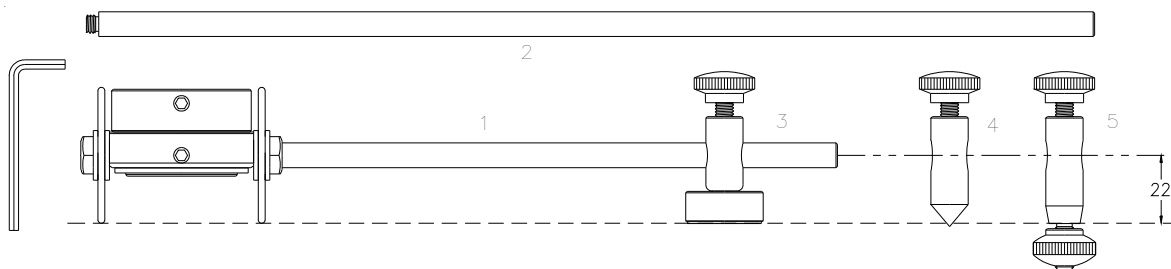

No.	Ref.	Code	Description	No.	Ref.	Code	Description
1		51820	Radius bar mm250			51851	Circle cutting attachment EWS [®] EX100 [®]
2		51821	Radius bar mm400			51807	Cutting guide EWS [®] EX100 [®]
3		51831	Magnetic base assembly			51852	Circle cutting attachment HY [®] MAX80/100 [®]
4		51832	Free centering straight pin			51808	Cutting guide HY [®] MAX80/100 [®]
5		51833	Straight locking pin			51857	Circle cutting attachment TD [®] PCH51 [®]
169		51851	Circle cutting attachment CEB [®] P150 [®]			51813	Cutting guide TD [®] PCH51 [®]
155		51807	Cutting guide CEB [®] P150 [®]			51867	Circle cutting attachment CEB [®] CP200 [®]
		51851	Circle cutting attachment TRA [®] A101 to A151 [®]			51824	Cutting guide CEB [®] CP200 [®]
		51807	Cutting guide TRA [®] A101 to A151 [®]				

Torch side

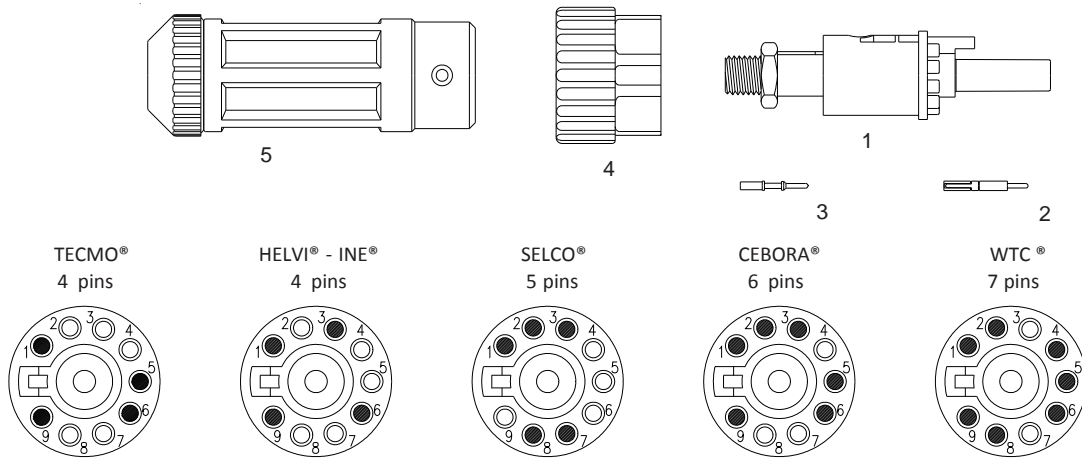

More lay-out on request

No.	Code	Description	No.	Code	Description
	04260	Central adaptor 4 pins TEC.MO®	1	04260.10	Adaptor body without pins
	04260-TRA	Central adaptor 4 pins HELVI® - INE®	2	04260.22	Male/Female pin connector
	04260-SEL	Central adaptor 5 pins SELCO®	3	04260.23	Contact pin
3.080.156	04260-CEB	Central adaptor 6 pins CEBORA®	4	04260.20	Adaptor nut
	04260-WTC	Central adaptor 7 pins WTC®	5	04260.21	Adaptor support
	04260.00	Central adaptor without pins			

Machine side

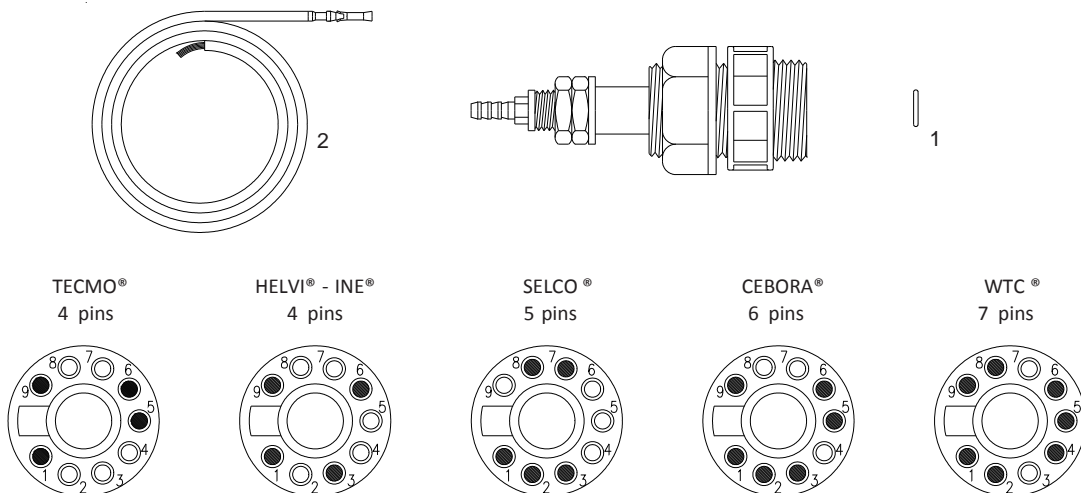

More lay-out on request

No.	Code	Description	No.	Code	Description
	04265	Central adaptor 4 pins TEC.MO®		04260.00	Central adaptor without pins
	04265-TRA	Central adaptor 4 pins HELVI® - INE®	1	04265.20	O - Ring
	04265-SEL	Central adaptor 5 pins SELCO®	2	04265.21	Contact pin, black lead, 1mmx500mm
3.080.156	04265-CEB	Central adaptor 6 pins CEBORA®		04265.22	Contact pin, red lead, 1mmx500mm
	04265-WTC	Central adaptor 7 pins WTC®		04265.23	Contact pin, blue lead, 1mmx500mm

Torch head with 7/16-24 fitting

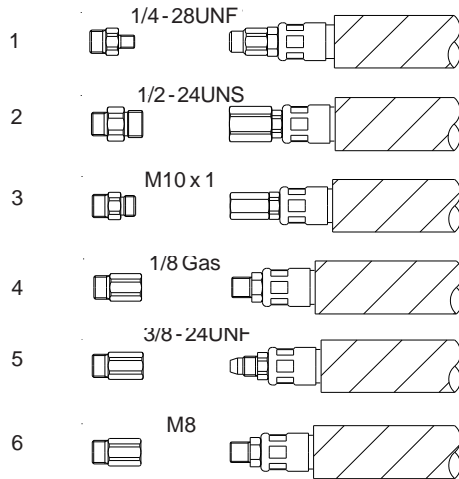
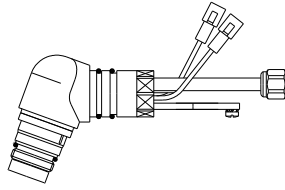

Torch head with 1/8 Gas fitting

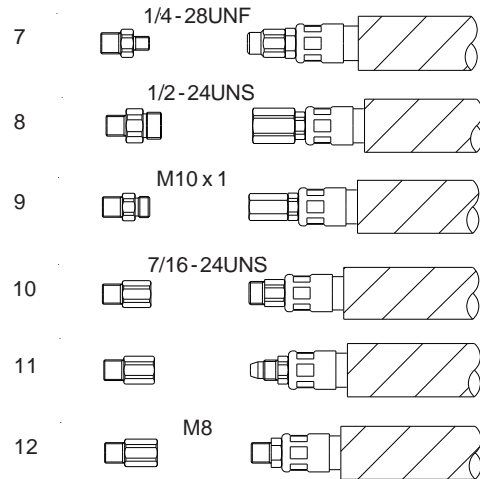
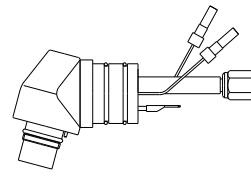

No.	Code	Description	No.	Code	Description
1	04293.40	THERMAL DYNAMICS® PCH-35/40	7	04292.40	THERMAL DYNAMICS® PCH-35/40
2	04293.41	THERMAL DYNAMICS® PCH-51	8	04292.41	THERMAL DYNAMICS® PCH-51
3	04293.42	TRAFIMET® 90	9	04292.42	TRAFIMET® 90
4	04293.43	CEBORA® 50/70/90 TRAFIMET® 60/80	10	04292.43	THERMAL DYNAMICS® PCH-60/75/76/80/100XL/102
5	04293.44	CEBORA® 150 TRAFIMET® 140/145 W.T.C.® BINZEL® 30/31	11	04292.44	CEBORA® 150 TRAFIMET® 140/145 W.T.C.® BINZEL® 30/31
6	04293.45	SAF® 150	12	04292.45	SAF® 150

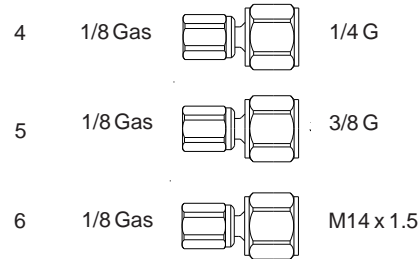
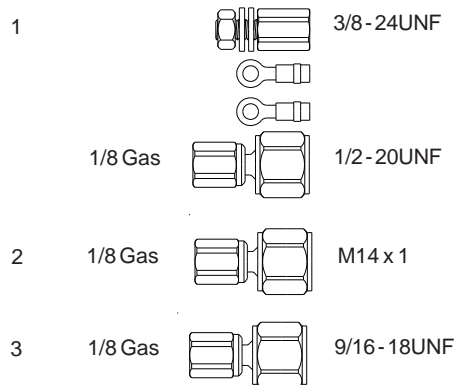

No.	Code	Description	No.	Code	Description
1	04276	HYPER THERM® - Max 40 - 80/100 ESAB® - LPC50 - LPC100	4	04270	BINZEL® PSB31-PSB31KK -60-80 TBI®
2	04272	TRAFIMET® 90 - 140 - R145 SAF® - CP40R - CP100R WTC® 20-120 & 100-150	5	04271	TRAFIMET® A53-S54-A60 BINZEL® PSB30
3	04275	THERMAL DYNAMICS® TELWIN® CEM®	6	04273	HELVI®

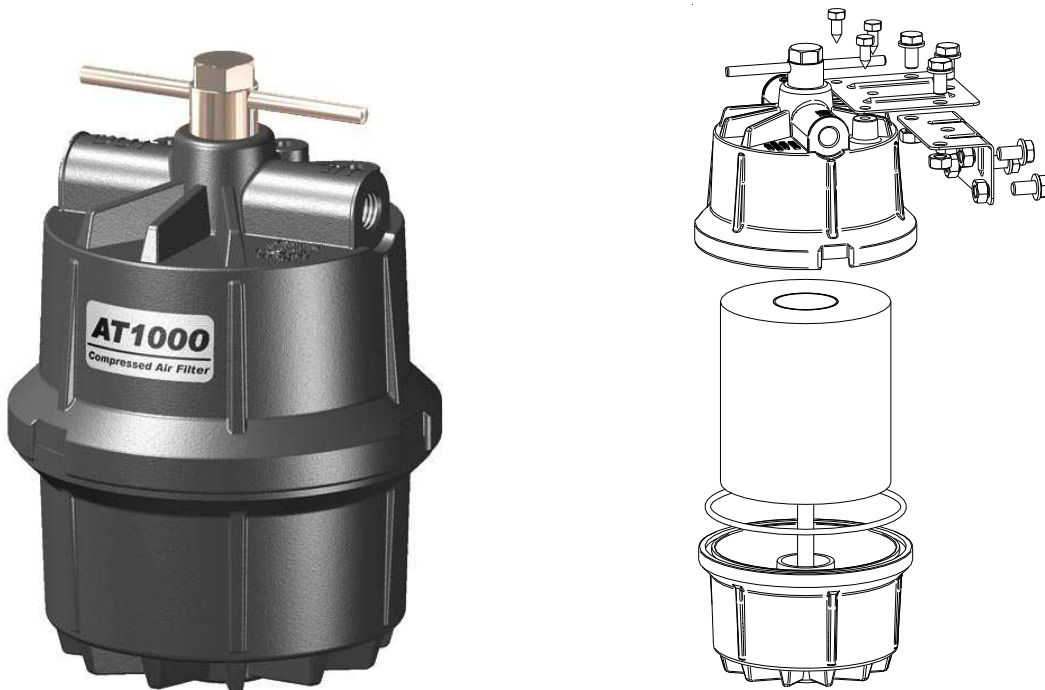

Code	Description	Packaging
50500	Air filter complete - ready to fit	1 box x 12 pieces (packed individually) dimensions: 44x30xh47 (Kg 17.8)
50505	Filter cartridge	1 box containing 6 boxes x 8 (total 48 pieces) dimensions: 66x44xh25 (Kg 12)

HYPERCOOLANT Circuit Cooler



Code	Description	Packaging
50001	Hypercoolant - Circuit cooler (5 Lt)	1 box x 4 pieces dimensions: 44x30xh30 (Kg 20)

